

JAN. 24

1931

15 Cents

Per Copy

**RADIO**

REG. U.S. PAT. OFF.

**WORLD**

The First and Only National Radio Weekly

*461st Consecutive Issue—NINTH YEAR*

---

**TOY  
DANCES  
WHEN  
SPEAKER  
PLAYS**

---

RADIO WORLD, Published by Hennessy Radio Publications Corporation. Roland Burke Hennessy, editor; Herman Bernard, managing editor and business manager, all of 145 West 45th Street, New York, N. Y.

---



**TRY-MO SPECIALS**

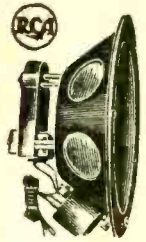

**R. C. A. CHASSIS**

This Chassis is identical with that used in the RCA model BDA-100B-103 Speakers. This speaker has built-in output filter and will stand 450 volts without "bias" or distortion. The metal frame is lined with a special self-buffing material and the cone surface is corrugated enhancing the tonal reproduction. This Chassis is also ideal for automobile installation **\$3.75**

**B. B. L. AUTO SPEAKER**

A very sensitive speaker employing the BBL unit for perfect clarity and immense volume, housed in a highly attractive cabinet, size 10" wide by 3 1/2" deep, equipped with a 5-ft. cord. The speaker therefore is highly compact and suitable for placement anywhere in an automobile. Price..... **\$6.95**



**PEERLESS AC DYNAMIC**



A genuine AC Peerless Dynamic speaker in a genuine Peerless cabinet, suitable for use with any receiver. This is the famous Giant Peerless, the list price of which was \$75. Perfect reproduction over the full musical register is assured. The speaker has special capability of handling enormous volume without rattling or any other form of disturbance. The cabinet is of Gothic design of extreme beauty. The speaker is Model 19A for 110 volt, 50-60 cycles. Price **\$14.95**

**FARRAND MAGNETIC IN PEERLESS CABINET**

One of the most famous makers of magnetic units was Farrand Manufacturing Co. Their specially fine unit is housed in an attractive Peerless Gothic cabinet, and the combination affords the utmost obtainable for such a low price. The unit is sensitive in the lower register as well as over the rest of the musical scale, and has a special method of construction that overcomes the low note attenuation experienced with some magnetic units. The cabinet is a famous Gothic model 7A of the Peerless line, while the Farrand chassis is the one that was designed for inclusion in expensive installation. Price..... **\$4.95**



**B. B. L. MAGNETIC CHASSIS**

Employs the well-known BBL magnetic unit made by the Best Manufacturing Co. The diaphragm is Burtex and the framework is metal. Extreme compactness. 5-ft. cord. The unit adjustment is especially secure and the armature will not strike the pole pieces, thus assuring you all absence of rattling. 9" diaphragm List price, \$8.00. Your price **\$4.72**  
10 1/2" diaphragm—List price \$10. Your price **\$5.98**



**DUO-MAGNETIC UNIT**

This unit has twin magnets mounted in parallel position and more than double the power that would be obtainable if only one unit were used. The assembly is extremely rigid and the coils are wound with such a generous inductance that not only is the sensitivity very great but also it is remarkably even over the musical scale, permitting full depth of response to low notes, which are slighter on some magnetic units. The Duo Magnetic Unit has been standard for nearly three years and is recognized as one of the best magnetic units ever made. List price \$10.00. Your price **\$3.25**



**EFFICIENT TONE CONTROL**

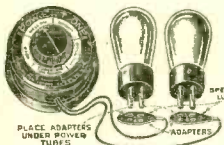

The Powertone Tone Regulator embodies features of design that make it a real tone control, actuated on the grids of the power tubes. Control on the grids gives a larger degree of tone regulation. Provision is made to allow the connection of extra speakers. This is a real convenience and a distinct Powertone feature. Available in table and panel mounting styles, and for push-pull output and single power stage. Price (push-pull) **\$1.95**

**PHONOGRAPH MOTOR**

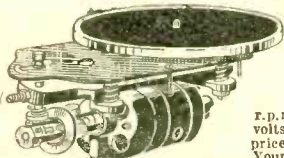

Shaded pole induction motor, 20 watts. Starts immediately on turning on switch. Variable speed, 70 to 95 1/2 r.p.m. 110 to 120 volts. 50-60 cycles. List price \$25.00. Your price **\$12.45**

**TRY-MO RADIO CO., INC.**

(Two Stores)  
177 Greenwich St., near Cortlandt St.  
80 Cortlandt St., near Washington St.  
NEW YORK, N. Y.

**DEALERS and SERVICE MEN!**  
STANDARDIZE ON



For Permanent Replacement—Accurate—Guaranteed  
Write for descriptive catalogue "W"  
LYNCH MFG. CO., INC., 1775 Broadway, New York

**RADIO MAP**  
OF NORTH AMERICA

22 x 22 inches, printed in two colors, bound in cover.

Shows every city from Balboa to Edmonton which has a broadcasting station.

Indexed by states, provinces and cities with key for instant location on map.

Call letters, power and frequency given for each station.

**Accurate; up-to-date**

Scale in miles gives distances between any two cities. Time zones correctly marked.

Just what you have been wanting.

**25 cents**

**THE RADEX PRESS**

1368 E. 6th St. Cleveland, Ohio

**HAYDEN'S DANDY MIDGET—**  
All parts, including cabinet, **\$22.46.**  
Guaranty Radio Goods Co., 143 W. 45th St., N. Y. C.

**Save Money on Tubes!**

**Get a Guarantee Just the Same!**

**Q**UANTITY tubes at enormously reduced prices enable you to save money and obtain full satisfaction. Any tube will be replaced on request within thirty days of its sale!

These tubes are made by a manufacturer of national reputation and are not "distress merchandise." No tube is shipped until it is carefully checked on a Readrite No. 9 Radio Test Kit.

Type	List Price	Your Cost	Type	List Price	Your Cost	Type	List Price	Your Cost
<input type="checkbox"/> 201A	\$1.25	49c	<input type="checkbox"/> WD-12	\$3.00	59c	<input type="checkbox"/> 245	\$2.00	59c
<input type="checkbox"/> 226	1.75	49c	<input type="checkbox"/> 200A	4.00	59c	<input type="checkbox"/> 280	1.90	59c
<input type="checkbox"/> 199-UX	2.50	59c	<input type="checkbox"/> 171A	2.25	59c	<input type="checkbox"/> 224	3.30	59c
<input type="checkbox"/> 199-UV	2.75	59c	<input type="checkbox"/> 171AC	2.25	59c	<input type="checkbox"/> 222	4.50	95c
<input type="checkbox"/> 120	3.00	59c	<input type="checkbox"/> 112A	2.25	59c	<input type="checkbox"/> 281	7.25	95c
<input type="checkbox"/> WD-11	3.00	59c	<input type="checkbox"/> 227	2.20	59c	<input type="checkbox"/> 210	9.00	95c

250, List \$11.00, your cost, 95c.

[Remit with order for tubes and we pay postage]

**DIRECT RADIO CO.**

143 West 45th St., New York, N. Y.

**Like Oil on Troubled Waters**

**ELECTRAD**

Resistors and Voltage Controls

overcome and pacify many acute and irritating radio difficulties. They are the choice of men who demand quality, performance, service—and correct price.

Write for New, Complete Electrad Catalog. Enclose 10c.  
Dept. RW-1-24

175 Varick St., New York, N.Y.  
**ELECTRAD**  
INC.

**New—Liquid Soldering Flux**

Cleaner, quicker than paste. Enables anyone to make joints like a professional. Saves time and temper. Sample bottle 10c coin. Large bottle 50c.

FURMHOLD CHEMICAL CO.  
1128 - 81st St., Brooklyn, N. Y.

**Orders-Inquiries**

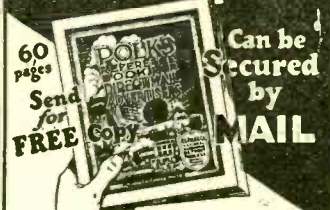

**POLK'S REFERENCE BOOK and Mailing List Catalog**

Gives counts and prices on over 8,000 different lines of business. No matter what your business, in this book you will find the number of your prospective customers listed. Valuable information is also given as to how you can use the mails to secure orders and inquiries for your products or services.

Write for Your FREE Copy  
R. L. POLK & CO., Detroit, Mich.  
Largest City Directory Publishers in the World  
Mailing List Compilers—Business Statistics  
Producers of Direct Mail Advertising

**Subscribers: watch the date line on your wrapper**

If the expiration date line on your wrapper indicates that your subscription has expired or is about to expire, please send in renewal so that you will not miss any copies of the paper. Subscription Dept., Radio World, 145 W. 45th St., N. Y.



**BUY NOW**  
While Prices Are Lowest!

Now all the fans who build their own sets or service men who are making replacements are using the dry electrolytic condenser. It affords high, lasting capacity in compact form. The lug at top represents the anode and goes to the positive side (B+ or C+), while the aluminum case is to go to the negative side, usually ground. The capacity of the condenser is 8 mfd. The condenser, a product of Aerovox, is admirably suited for use in filter circuits, for use on rectified AC or pulsating DC. The condenser must not be used on raw AC. Maximum peak voltage, 500 volts DC. Normal operating voltage, 400 volts DC. Dry, self-healing, high capacity, low leakage, unaffected by moisture. Size, 1-5/16" diam. 4 1/2" overall. Mounts in any position. Brackets supplied. Order Cat. AV-8 @ \$1.42

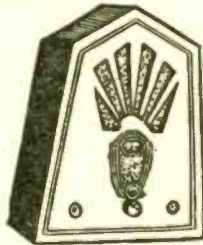
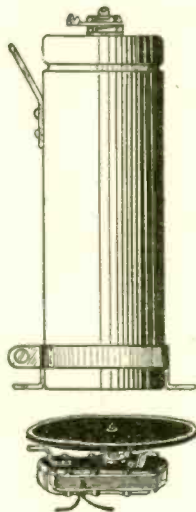

An outstanding example of the vastly popular midget receiver, not very much larger than any good speaker, yet it contains a very sensitive, efficient and powerful AC radio set, AC power pack and a speaker that would do justice reproducing the output of the most elaborate AC receiver! Startling statements, yes, but they are undeniable facts! Imagine, not even as large as most battery operated portable sets, and lighter in weight! The set will duplicate in performance (considering selectivity, sensitivity and volume) that of its much larger and more costly brothers! One dial tuning control, also switch and volume control knob (not illustrated.) Uses six tubes: three 224, one 227, one 245 and one 280. Perfect reproduction! Combined weight of entire set, speaker and tubes less than 20 lbs.! Entirely self-contained! 3 gang tuning condenser. Uses power tubes and push-pull electro-dynamic speaker! Durable built in handsome walnut case, with six tubes, cabinet speaker—nothing else to buy! Order Cat. MDST @ .....\$39.95

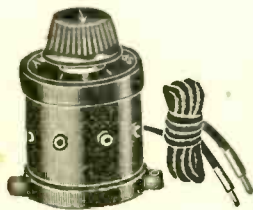
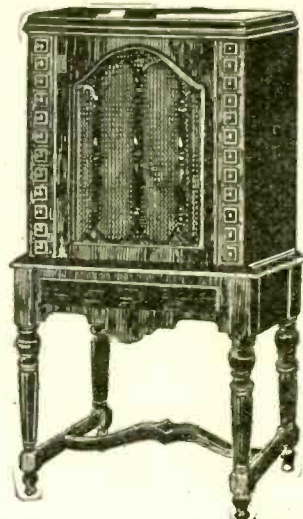

New Speakerrelay for connecting two speakers to it and playing either one (position No. 1, left); or the other (position No. 2, right); or both at once (position No. 3); by turning the knob. Built into an attractive black moulded bakelite case, with 18-inch connecting cords to the output posts of the receiver or amplifier. The speakers' cords are connected to the relay by plugging into built-in jacks. This device can be used also for switching from "phonograph pickup" to "radio." Order Cat. 131 @ .....\$1.10

Synchronous motor for 60-cycle lines, 105 to 120 volts, with turntable, producing 80 turntable revolutions per minute. Takes up to 21-inch records. Sturdy and compact. This motor is only 1 1/2 inches thick. Not affected by line voltage fluctuations. The compactness permits installation in consoles or any other available space. Made by Allen-Hough, makers of the Phono-link pickup. Shipping weight, 7 lbs. Order Cat. SYN-M (with turntable) @ .....\$4.25

**PHONOGRAPH \$3.32 PICK-UP**

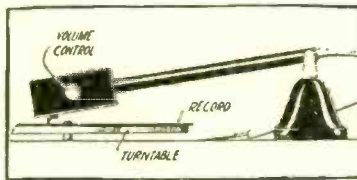

The famous Phono-link, made by Allen-Hough, enables playing phonograph records electrically, on your set. Volume control is built in. Adapter, free with each order, enables immediate connection to your set. Instruction sheet enclosed. Order Cat. PHL @ \$3.32.

Positively the last word in the most efficient and powerful reproducer model! As a fitting companion, it is housed in a truly exquisite deep two-tone walnut console, of rare beauty and craftsmanship! To properly baffle the ultra-powerful Peerless chassis, a chamber 15" deep, 17 1/2" wide and 18" high houses same. Front baffle of 3/4" thickness! Size of opening, 10 inches. Ideal for use with the most powerful public address amplifier. NO RATTLING, NO DISTORTION—JUST PERFECT REPRODUCTION! For that matter it is equally suited with ordinary sets, employing the average type of audio amplification systems. Order Cat. SSC @ .....\$24.80 (If cabinet only is desired (less speaker) order Cat. SCO @ .....\$13.44)



Bernard nippers. Drop-forged steel. Handiest tool for radio workers as wire-cutter, insulation stripper, and as screw-cutting. It will easily nip off protruding brass or iron screws up to 8/32 with easy hand pressure. A rugged, reliable and renowned instrument. Order Cat. BNP @ .....\$1.27



Here is the best buy of the year: A 1 1/2" diameter 110 volt D.C. dynamic chassis, with two field coil resistances, 800 ohms AND 4,000 ohms. Contains push-pull output transformer. Designed for use with any super-power amplifier—for auditorium reproduction. Shipping weight, 25 lbs. Order Cat. 1100 @ .....\$16.95



Natural bakelite tubing, made by Spaulding, in two diameters, 1 1/2 inches and 2 inches, outside diameters. One will fit inside the other even after wire is wound on the smaller diameter. Length Diam. Price 24" 1 1/2" .....\$0.09 36" 2" ..... .12 36" 2 1/2" ..... .40 The 1 1/2" length, 1 1/2" diameter, can be used for winding a primary, and be inserted.

**Temple Dynamic \$15.34 Beautiful Carved Wood Grille Front**



This is one of the finest dynamic speakers ever made, and is highly recommended by us. AC switch is provided. A knob is built in for adjusting the speaker impedance to that of your set. An output transformer and dry rectifier are built in. Connect plugged AC cable to 110 volts AC, 50 to 60 cycles and connect typed cords to speaker post of receiver. This remarkable speaker The Temple 10 chassis in the fascinatingly decorative walnut cabinet, with carved grille ornament, as illustrated; both front and back finished. (Cabinet not sold separately). Order Cat. TEM @ .....\$15.34

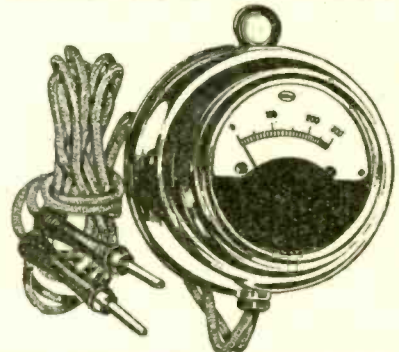

0-600 volts, high resistance; AC and DC (same meter reads both types). DC readings accurate to 2%, also AC readings 2% at 50-60 cycles, but accuracy is less on AC at substantially different frequencies. Order Cat. F-600 @ .....\$4.95 0-300 volts, high resistance. Accuracy, 2%. Case is full nickel finish. Long connecting cords have especially ornamental tip holders. Meter should be read in perpendicular position. Order Cat. F-300 @ .....\$2.50 0-500 volts, same as above in appearance, but the range is greater. Order Cat. F-500 @ .....\$3.73

**EXTRA-SPECIAL SPECIALS!**

- (Cat. SPEC-1)—Eris DC dynamic chassis, 9-inch cone, for operation from 6-volt storage battery. Connect speaker-tipped cords to output of set, and connect twisted pair to 6-volt storage battery. Draws 1/2 amp. Price.....\$9.00
- (Cat. SPEC-2)—Wave trap, for cutting out interference. Connect aerial to one side of the trap, other side to antenna post of receiver from which aerial was removed, and tune out interfering stations. A great selectivity booster. Price..... .87
- (Cat. SPEC-3)—Rider's Supplement No. 1, containing diagrams supplemental to those in Rider's "Trouble Shooting Manual," and an invaluable addition, for completeness, to any who possess Rider's manual. Price..... 1.22
- (Cat. SPEC-5)—Dubilier .01 mfd. fixed mica condenser..... .10
- (Cat. SPEC-6)—Dubilier .00025 mfd. mica fixed condenser, with clips for grid leak mounting..... .11
- (Cat. SPEC-7)—.0001 mfd. Dubilier fixed condenser, for connection in series with aerial to improve selectivity..... .11
- (Cat. SPEC-8)—Power transformer, with two chokes built in for B filtration. Primary, 105-125 volts, 50-60 cycles; secondaries, all center-tapped with red leads, are for high voltage for 280 w. work 245 tubes, single or push-pull, and rest of tubes in set up to 100 mba; 300 volts DC output; 2 1/2 volts 2 amps. for 245s, single or push-pull; 2 1/2 volts 14 amperes, for 227s and 280s, up to 8 of these; 5 volts for filament of 280. All, including chokes, in one cadmium plated steel case. Leads identified. Chokes are 30 henries each..... 7.50

**Special "Buy-Now" Bargain Coupon!**

GUARANTY RADIO GOODS CO., 143 West 45th Street, New York, N. Y. (Just East of Broadway)

- Please ship at once the following:
- Cat. AV-8 @ .....\$1.42
  - Cat. MDST @ .....\$39.95
  - Cat. 121 @ ..... 1.10
  - Cat. SYN-M @ ..... 4.25
  - Cat. PHL @ ..... 3.32
  - Cat. SSC @ ..... 24.88
  - Cat. SCO @ .....\$13.44
  - Cat. 1100 @ ..... 16.95
  - Cat. 719 @ ..... 14.95
  - Cat. 720 @ ..... 15.95
  - Cat. 721 @ ..... 8.95
  - Cat. 1020 @ ..... 9.95
  - Cat. 1021 @ .....\$11.95
  - Cat. 1022 @ ..... 9.95
  - Cat. 1023 @ ..... 7.95
  - Cat. 1024 @ ..... 7.95
  - Cat. BNP @ ..... 1.27
  - Cat. TEM @ ..... 15.34

**METERS**

- Cat. F-600 @ ..... 4.95
  - Cat. F-300 @ ..... 2.95
  - Cat. F-500 @ ..... 3.73
- EXTRA-SPECIAL SPECIALS!**
- Cat. SPEC-1 @ .....\$9.00
  - Cat. SPEC-2 @ ..... .87
  - Cat. SPEC-3 @ ..... 1.22
  - Cat. SPEC-5 @ ..... .16
  - Cat. SPEC-6 @ ..... .11
  - Cat. SPEC-7 @ .....\$8.11
  - Cat. SPEC-8 @ ..... 7.50

Name .....  
Address .....  
City ..... State .....

(Above prices are on basis of remittance with order, but if C. O. D. is desired, if you enclose 1/4 of total amount, shipment will be made C.O.D. for balance.)



# POLO

## 245 POWER TRANSFORMER

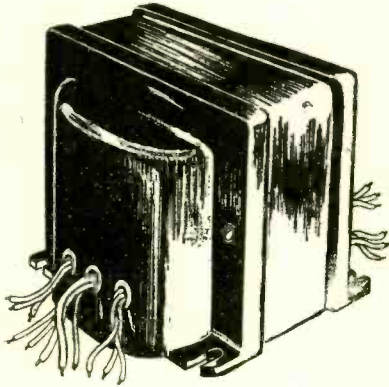

CAT. 245-PT. PRICE, \$9.50

THE 245 power transformer is for use with a 280 rectifier tube, to deliver 300 volts DC at 100 milliamperes, slightly higher voltage at lower drain, from 105-125-volt AC line (marked 110 v.), 50-60 cycles. The primary is tapped at 82½ volts in case a voltage regulator (Clarostat or Amperite) is used. The black primary lead is common. If no voltage regulator is used the other primary lead is the green one. If regulator is used, the red and black form the circuit. The secondary voltages are all center tapped: 672 volts AC for 280 plates, 2½ v. 3 amps. for 245 output, single or push-pull; 5 v. 2 amps, for 280 filament; 2½ volts 16 amps. for up to eight 224 or 227 tubes. Center taps are red and all leads are identified on name plate. Laminations are hidden except at bottom. Eight-inch leads emerge from the sides, but if preferred may be taken off through the bottom of the transformer by pushing them through the rubber grommets. Shipping weight, 12 lbs. Overall size: 5" extreme width x 4½" high. Order Cat. 245-PT @ \$9.50

## 245 B SUPPLY CHOKE

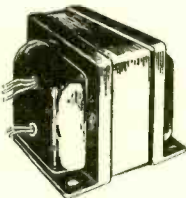

Cat. 245-CH Price, \$4.00

100 ma choke coil for B filtration in 245 circuits; 200 ohms DC resistance, inductance 30 henrys. A continuous winding (tapped in two places, giving three sections and four out-leads, and permitting a "choke input" to filter. By this method rectifier tube life and filter condenser life are lengthened yet filtration is splendid. The black lead goes to the rectifier filament center, the red, green and yellow leads are next in order. Capacities suggested: black, none; red, 1 mfd.; green, 8 mfd.; yellow, 8 mfd. In shielded, polished aluminum case. Shipping weight, 4 lbs. Order Cat. 245-CH @ \$4.00.

## SPECIAL FILAMENT TRANSFORMER

105-120 v. 50-60 cycles, with two secondaries, one of 2½ v., 3 amp. for 245s, single or push-pull, other 2½ v. 12 amperes for up to six 224, 227, etc., both secondaries center-tapped. Shielded case, polished aluminum, same as 245-CH illustrated. 6 ft. A.C. cable, with plug. Shipping weight, 4 lbs. Order Cat. SP-FLT (4 lbs.) @ \$4.25.

## SHORT-WAVE CONVERTERS

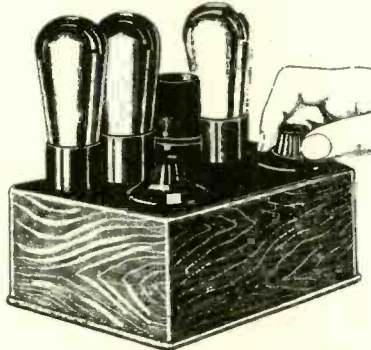

CAT. 3-FS. PRICE \$9.58

EFFICIENT AC all-wave converter, 15 to 600 meters with total of only two plug-in coils, is Cat. 3FS, illustrated. Filament transformer built in. Three 227 tubes used. One tuned circuit. Hammarlund condenser. Equipped with AC switch. Works with any broadcast receiver, either TRF or Superheterodyne. No molestation of receiver. No grunting, body capacity or squeals. The circuit used is the one illustrated in Fig. 2 on page 14 of this week's issue, while the parts are exactly as specified by Herman Bernard. The resultant sensitivity when this converter is used with any good set is very high, and users report the reception of very great distances. Order Cat. 3-FS (all parts, including filament transformer and cabinet, but not tubes) \$9.58 [Wired Model, Cat. 3-FS-W @ \$12.58]

## DE LUXE MODEL

The de luxe model short-wave converter, using the circuit Fig. 3 on page 15 this week, is a beautiful bakelite chassis with National modernistic dial, two tuned circuits with Hammarlund condensers, and using a total of five plug-in coils. This model, the 1-A, tunes from 15 to 600 meters and uses three screen grid tubes. Order Cat. 1-A (all parts, including filament transformer and tube base coils) \$19.87 [Wired model, Cat. 1-A-W, @ \$22.87] Precision coils, wound on air, @ \$1.10 extra.

## SHORT-WAVE FILAMENT TRANSFORMER

We manufacture the filament transformer specified by Herman Bernard for the Super-tone Short-Wave Converters. The primary is 110 v., 50-60 cycles; secondary, 2½ volts, 8 amperes. No center tap is necessary. Order Cat. SW-FLT @ \$2.50 For 40 cycles, Cat. SW-FLT-40 @ \$3.20 For 220 v., 50-60 cycles, Cat. SW-FLT-220 @ \$3.00

**POLO ENGINEERING LABORATORIES**  
125 WEST 45TH STREET  
NEW YORK, N. Y.

## Quick-Action Classified Advertisements

7c a Word — \$1.00 Minimum  
Cash With Order

**SMALL MOTOR GEN.** 3 phase, 220 to 7½ volts D.C. Like new, \$75. R. Campbell, 365 Edgewood Ave., New Haven, Conn.

**FOR SALE HiQ 30 CHEAP.** F. L. Hanson, Iliion, N. Y.

**POWER UNIT CONSTRUCTION**—The book that enables you to wind your transformers, chokes, and figure correct size resistors for the voltage control and other valuable information. Price .50. Shipped C. O. D. Ralph B. Davis & Co., Prestonsburg, Ky.

**BARGAINS** in first-class, highest grade merchandise. B-B-L phonograph pick-up, theatre type, suitable for home with vol. control, \$6.57; phono-link pick-up with vol. control and adapter, \$3.32; steel cabinet for HB Compact, \$3.00; four-gang .00035 mfd. with trimmers built in, \$1.95; .00025 mfd. Dubilier grid condenser with clips 15c. P. Cohen, Room 1214, at 143 West 45th Street, N. Y. City.

**CHOICE FLORIDA ORANGES, GRAPEFRUIT AND TANGERINES.** Full standard bushel, straight or assorted, \$1.75 with order, express charges collect. Medium grade oranges \$1.25. Mrs. Helen Thomas, Box 210, Thonotosassa, Florida.

**FLORIDA FRUIT BOX** containing 45 oranges, 12 grapefruit, 20 tangerines, 100 kumquats, jar fruit preserves. Express prepaid anywhere, \$3.00. Florida Fruit Growers Packing Company, P. O. Box 282, Tampa, Fla.

**RESISTANCES, CONDENSERS, TRANSFORMERS, CHOKE-COILS,** etc. Write for sensational low price list. Bronx Wholesale Radio Company, 5 West Tremont Avenue, New York.

**"A B C OF TELEVISION"** by Yates—A comprehensive book on the subject that is attracting attention of radioists and scientists all over the world. \$3.00, postpaid. Radio World, 145 West 45th St., N. Y. City.

**EXPERT CONSTRUCTIONAL DATA** — Power transformers 245 and 250, .50 each. Cores supplied. Radio Power, 1028 Forest Road, Schenectady, N. Y.

**SILVER MARSHALL 712 TUNER** with tubes \$25.00, complete. J. D. Avery, 245 Federal St., Greenfield, Mass.

**HORN UNIT, \$2.25**—This is the Fidelity Unit and has stood the test of time. Guaranty Radio Goods Co., 143 W. 45th St., New York.

**MAGICALLY CLEANS FALSE TEETH—WATAJOY Wonder Cleaner.** Instantly removes film. Cleans and purifies plate. Approved by licensed chemist. Costs about 5c per mo. A big treat awaits you. Prepaid 25c. WATAJOY LAB., Alhambra, Cal.

**"MATHEMATICS OF RADIO."**—A great help to everybody interested in radio. \$2 postpaid. Radio World, 145 W. 45th St., N. Y. City.

## TUNER ASSEMBLIES

A tuning condenser with coil to match, mounted on an aluminum base that has socket built in. The condenser shaft goes in a dial (not furnished). The tuned circuit includes a fixed and a movable winding (rotor coil) in series. The moving coil is used as a trimmer, set once and left thus, so two separate dials are made to read alike, or gang tuning is made practical. No equalizing condensers needed. Do not couple the adjoining shafts.

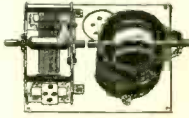

For antenna circuit, input to 226, 201A, UX199, 240, 230, 232 and 222, or any other tube fitting four-prong UX socket, or for interstage coupling for 226, 201A, 199, 240 or 230, but NOT interstage for 232 or 222, order cat. BT-L-DC @ \$1.25

For interstage coupling for 232 and 222, order cat. BT-R-DC @ \$1.25

For antenna circuit as RF input to 224 or 227, or for 227 interstage coupling, (five-prong UY socket furnished) order cat. BT-L-AC @ \$1.25

For interstage coupling for 224 (5-prong UY socket furnished, order cat. BT-R-AC @ \$1.25

## SCREEN GRID COIL CO.

143 West 45th Street, New York, N. Y.  
(Just East of Broadway)





Vol. XVIII. No. 19 Whole No. 461  
 January 24th, 1931  
 [Entered as second-class matter March, 1922, at the Post Office at New York, N. Y., under act of March, 1879]  
 15c per Copy. \$6.00 per Year

**NINTH YEAR**  
 Technical Accuracy Second to None  
 Latest Circuits and News

A Weekly Paper published by Hennessy Radio Publications Corporation, from Publication Office, 145 West 45th Street, New York, N. Y. (Just East of Broadway)  
 Telephone, BRyant 9-0558 and 9-0559

RADIO WORLD, owned and published by Hennessy Radio Publications Corporation, 145 West 45th Street, New York, N. Y. Roland Burke Hennessy, president and treasurer, 145 West 45th Street, New York, N. Y.; M. B. Hennessy, vice-president, 145 West 45th Street, New York, N. Y.; Herman Bernard, Secretary, 145 West 45th Street, New York, N. Y.; Roland Burke Hennessy, editor; Herman Bernard, business manager and managing editor; J. E. Anderson, technical editor

# Speaker Makes Toy Dance

By J. E. Anderson

**I**T IS a simple device that is depicted in Fig. 1, yet it is closely connected with such subjects as ships colliding on meeting in a harbor, hydraulic pressure gauges, the flight of an airplane, a baseball curve, the propulsion of a rotor ship, and Bernoulli's principle.

The device in Fig. 1 is a toy, but it is a toy that makes father a boy again and therefore one that is quite fitting to give to sonny for a Christmas present. It is as funny as a Punch and Judy show, and it appeals to the entire family from grandma to the baby.

What is it? A frame of wood or metal about 2½ inches by 2 inches. In the center of the frame are stretched two parallel fibres or light threads and to each of these are glued curved pieces of paper. The proper shape is semicircular with the convex surfaces of the two facing each other. The construction and size of the devices are shown more clearly in Fig. 2 where it is compared with a dynamic loudspeaker.

## How It Works

In the first paragraph we mentioned a number of diverse subjects, claiming that the present little device is related to all of them, and closely at that. They are all related because they are all applications of Bernoulli's principle. We could mention many other phenomena which belong to the same family. We shall mention one other—a ping pong ball riding the top of a vertical jet of water. Why does not the water throw it off? We shall not answer that specifically but let us proceed with a brief explanation of Bernoulli's principle.

Suppose we mount two ping pong balls on two parallel strings like the curved pieces of paper in Fig. 1. Let us say that the nearest points of the balls are quarter inch apart. As long as they are not disturbed they stay that distance apart and remain perfectly still.

Now we know that if we blow on one of the balls it will move away in the direction of the air current. If the air current is steady the ball will simply be displaced a little, but moved farther, the more intense the air current. Now then, let us direct the air between the balls suspended as described above. The jet or air should force the balls apart just as if they were driven apart by a wedge. Any objections to that conclusion? There is no objection unless you happen to know Bernoulli's principle.

## A Pair of Perverse Balls

If we actually fill our lungs and blow hard between the balls, they will behave in a very perverse manner, for instead of moving apart, they will slap each other hard. That is, they will, if the blowing was hard enough. In any event they will not move apart but they will always move toward each other. They will butt each other like a pair of rams if the blowing is hard enough and directed exactly between them.

Why do they do this? Because the air draught between the curved surfaces of the balls reduces the air pressure between them so that the pressure on the opposite sides is greater than that between the balls.

Now let us state Bernoulli's principle, which applies to air as well as water, or, in fact, to any fluid. We shall take a pipe for simplicity. Let the pipe consist of lengths of various cross sections and let there be a flow of gas or liquid through it. If we insert gauges in the sides of the various cross sections to measure the pressure, we shall find that the gauge inserted in a narrow part will read lower than one set in a wide section. The

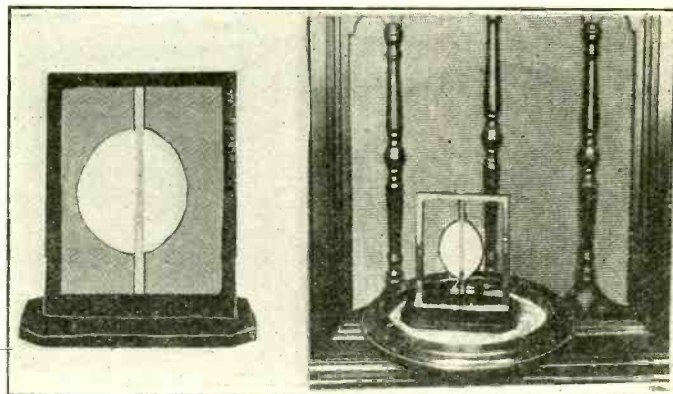

**Fig. 1**  
 A simple device that keeps time with the sound from the loudspeaker thus obeying Bernoulli's principle.

**Fig. 2**  
 The device placed in front of the loudspeaker. The sound creates the draught of air which causes the vibrations.

wider the section the greater will be the pressure against the side of the pipe. Since the same amount of fluid passes all sections in a given time it is clear that the velocity at the constricted parts will be much greater than at the wide parts. Hence we get the fact that the greater the velocity the less will be the pressure of the fluid against the side of the pipe. That is Bernoulli's principle.

The fluid does not have to be confined to a pipe at all, just so the conditions are such that the velocity of the fluid is greater on one side than on the other. In the case of the ping pong balls the jet of air was directed between the balls and therefore the velocity of the air between the balls was greater than on the other sides. Even if the jet had not been directed between the balls the effect would have been the same. For example, suppose there had been a strong wind with a motion of the air uniformly distributed. The curvature of the balls would have increased the velocity of the air between the balls. The curvature would also have increased the velocity outside, but only one-half as much. Hence the balls would have moved toward each other.

## Collision of Ships

When two ships are moving parallel to each other, either in the same direction or in opposite directions, the same situation arises. The curvature of the sides of the ship causes a higher water velocity, relative to the ships, between them than outside them. Hence there is a force tending to run the ships together.

In the airplane the upper part of the wing is curved so as to create a part vacuum over the wing and this produces the lift. A baseball that spins as it moves forward describes a curve because on one side the relative velocity of air and the ball surface is decreased and on the opposite side it is increased,



# The Band Pass Filter

By Herman

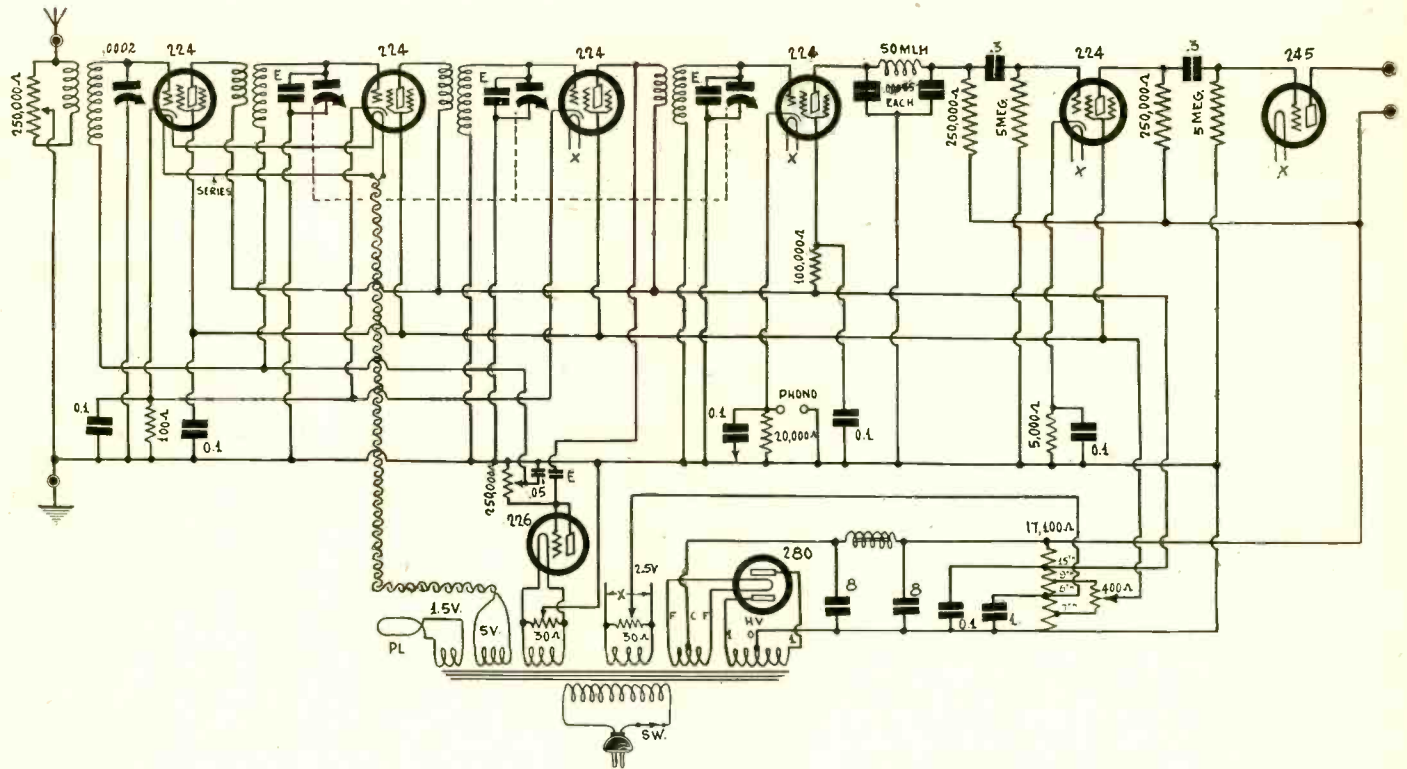

Fig. 1

The Band Pass Filter Diamond, with knob-actuated, individually tuned first stage.

**T**ROUBLE in getting the antenna stage tuning circuit to track with the others has been common. If one uses an entirely independent condenser of the same capacity and variation as found in the subsequent gang, the tuning curve of the gang and of the independent condenser, when compared, will show this difference. It is rather substantial at times.

One method of overcoming the trouble is to put a manually operated trimming condenser across the first section of a gang, when that section tunes the input to the first radio frequency tube. A device sometimes used, but which can not be considered really a method, is to ignore the situation entirely, with consequent reduction of sensitivity and selectivity.

### Helps You Get More DX

In the Band Pass Filter Diamond of the Air, diagrammed in Fig. 1 for AC operation, advantage is taken of the fact that a

### LIST OF PARTS

- One antenna coil, three interstage coils, all shielded.
- One three-gang .0005 mfd. variable condenser.
- One ¼-inch reducing coupler for condenser shaft.
- Four 20-100 mmfd. equalizing condensers (E).
- One 100-ohm flexible biasing resistor.
- One 100,000-ohm metallized pigtail resistor (0.1 meg.).
- One Hammarlund .0002 mfd. condenser.
- Two 250,000-ohm metallized pigtail resistors (0.25 meg.).
- Two 5.0 meg. metallized pigtail resistors.
- Two 250,000-ohm potentiometers.
- Two 30-ohm center-tapped resistors.
- Five 0.1 mfd. condenser blocks, three capacities to each block.
- One 1.0 mfd. bypass condenser.
- Two .00035 mfd. fixed condensers.
- One binding post strip (four posts).
- Two 8 mfd. dry electrolytic filter condensers.
- One power transformer with AC cable.
- One AC switch, shaft type.
- One subpanel with eight sockets.
- One National drum dial.
- One voltage divider, with 400-ohm potentiometer.

Note: The 0.5 mfd. is made up of two series-connected 0.1 mfd. The common black lead and one red lead are cut off for this purpose, and two reds used. The 0.3 mfd. consists of three 0.1 mfd. parallel-connected.

new small condenser has been produced by the Hammarlund Manufacturing Company, that works in a total diameter of 2 inches, so the antenna stage is independently tuned, but the condenser is actuated by a knob instead of by a dial.

Therefore the condenser may be set at minimum or maximum for service, if desired, as a sort of local-distance switch, besides being most useful in establishing exact resonance, and therefore enabling the reception of many distant stations otherwise missed.

### Plenty of Volume, Due to RF Gain

Besides, the selectivity is better because high negative bias is used with automatic volume control. The circuit is then as selective as modern conditions require.

Also, it will produce sufficient volume to work a loudspeaker well, even though the two audio-frequency stages are resistance-coupled. The screen grid detector, with proper resistance loads as specified—250,000 ohms in the plate circuit, 100,000 ohms in the screen circuit, 20,000-ohm bias resistor, and 5 meg. grid leak in the 245 circuit—permits about the same volume from the final output as if a general purpose tube were used with a high ratio transformer, but the quality is far better. The radio frequency gain is so high that the detector's bias voltage, or voltage handling capabilities, may be taxed, one some locals, and

## How to Trace Down

(Continued from preceding page)

ling feedback, and other disturbances, and will be found a most reliable indicator for the trouble shooter who has to treat cases in this category.

The coil that is best for radio frequency work alone is the solenoid, preferably the single layer type, but if the coil is to be poked into small spaces it cannot be large at all, so for this purpose it is best to select the same type of winding as previously discussed. The adjacent wires are to be separated about ¼ of an inch, but the fibre tubing inside diameter is 1¼ inches. The wall is 1/16 inch and the successive layers are to be collodion coated as before. The best plan is to make up several coils, of the honeycomb type, and tune them all with a .00025 condenser, or if you want to try it you can mount one of the larger midget type variable condensers, and the rectification may be by means of a fixed crystal, of which there are many, and the cost is low.

If hum distortion is being emitted by the speaker, place the



# Diamond of the Air

Bernard

it is therefore no trick at all to load up the 245 tube, although the 50-volt bias on that tube allows for a 100-volt fluctuation in the previous plate circuit.

You will notice that the voltage applied to the detector plate load is the maximum voltage from the B supply, which is around 300 volts, less bias, and screen resistor, 100,000 ohms, returned to the 180-volt lead. This properly apportions screen and plate voltages, and also provides the proper biasing voltage, due to the flow of screen and plate currents through the 20,000-ohm biasing resistor.

## Uses Four Tuned Circuits

It is not difficult to attain the very pinnacle of quality with such a hookup, the only provision being that the circuit should not oscillate at radio frequencies. It will not motorboat. The voltage for the screens of all three of the radio frequency tubes is critical, in respect to oscillation, and therefore those taps on the voltage divider were selected for connection of the voltage control that would keep oscillation well in check.

So, in this circuit, you have four tuned circuits, one of which is independently tuned. What is the advantage of independent tuning you will find out quickly, after you have operated the receiver a few minutes.

The first and second stages are inter-coupled, due to the return of the tuned circuit of both stages through the .05 mfd. condenser in the automatic volume control tube (226). The capacity of .05 mfd. is made up of two sections of a triple 0.1 mfd. condenser block, with the black common lead and any one red lead cut off, the two remaining red leads being used, the resultant capacity being half of 0.1, or .05 mfd. This provides the proper admittance band for the band pass filter introduced in the first and second radio frequency amplifying stages.

## This Circuit Has Only 2% Hum

The rest of the circuit has no novelties, except perhaps the connection of the heaters of the first two tubes across a 5-volt AC source. This is simply an example of connecting the heaters of these two tubes in series. The power transformer's 2½-volt winding will not provide full 2½ volts if all five heater tubes are worked therefrom, so the extra 5-volt winding is used, it being all right to connect heaters in series. No hum results.

On the subject of hum, due to the high capacities used in the filter section, 8 mfd. each, and the 30-henry choke coil, it is utterly impossible to hear any hum at all at a distance of 5 feet from the speaker, even with no signal tuned in. Even with the ear placed directly in front of the speaker, the hum is faint, almost inaudible.

It is considered permissible to have a hum component of 5 per cent. in an AC receiver, yet in this particular set the hum component is less than 2 per cent. While many will not find a little hum objectionable, since voice and music will drown it out, nevertheless the goal was to make the hum component so very low that even those who object to a little of it have no cause whatsoever for complaint on this score. No matter how severe your demand may be for hum-absence, this receiver will gratify it fully.

## Attainment of Proper Voltages

Attainment of proper voltages is very important in this receiver, but the solution has been made, and it is as follows:

Use a Multi-Tap Voltage Divider. This has taps affording twenty different voltages. The terminal lug at one end, where the lugs are more numerous, goes to ground. The extreme lug at the other end goes to the output of the filter choke. The center of the 2½-volt winding goes to the eighth tap from ground on the voltage divider, counting the ground tap and including it as the first, while a potentiometer, 400 ohms or more, is connected between the seventh and the ninth taps, that is, across these two positions. The correct screen voltage, admittedly critical, is obtained in this way, and once determined, is not molested thereafter.

The 180-volt tap is taken from the fifteenth lug from ground, counting the ground lug as the first, and counting two interconnected lugs as one. The voltage divider consists of two resistors in series, totalling 17,100 ohms, with a wire soldered at the factory from the extreme of one unit to the extreme of another unit. This is the one meant when the "interconnected lugs" are cited. The 180-volt connection is not critical, but the lug second from the 300-volt end cannot be used, although any one of the four other lugs on the way down to ground may be selected. It is just as well, however, to adhere to the 15th tap, as prescribed.

The method used in determining the correct tap for returning the center of the 2½-volt winding was as follows: With the 245 tube in circuit, return made to some estimated position, the voltage across the divider was measured, and proved to be 297 volts. This passes for the 300 volts recommended for total grid-plate voltage for the 245. Then the return was removed and a 0-100 milliammeter was connected in series with the wire coming from the center of the resistor across the 2½-volt winding, and the return made to that point on the voltage divider that produced a reading of 32 milliamperes.

## Bias Voltage Checked

The total voltage was rechecked at 297 volts. At 250 plate volts and 32 milliamperes of plate current, the bias on a good 245 tube will be 50 volts negative. When a 0-100 voltmeter was put across the section of the divider used for biasing, a meter with a resistance of 2,000 ohms per volt, the reading proved to be 49.7 volts, so the accuracy was even closer than requirements, as 5 per cent. variation is permissible.

With regard to the bias for the radio frequency tubes, this was made a little higher than standard because of improved selectivity and as a further safeguard against cross-modulation due to overloading of the radio amplifiers. So great is the gain of the 224 tube that overload preliminary to the detector may result unless the bias is somewhat higher than the usual requirement, and the 226 automatic volume control tube doubly takes care of this.

The band pass filtration arises from unison of two circuits. In the first instance the tuned circuit is completed through the biasing system of the second tube. Through this biasing resistor passes the second tube's plate current, so the union is established that way.

The power transformer has the rectifier voltage sources on one side, 5 volts (F-C-F) and high voltage (1-0-1), both windings center-tapped.

On the opposite side are the 2½-volt, extra 5-volt and two 1½-volt windings. On this side none of the windings is center-tapped.

## Data for Winding the Coils

The coils have to be shielded, of course. Drawn aluminum circular shields of 3-inch diameter were used. These did not drop the inductance below that required for coverage of the broadcast band with .0005 mfd. condensers.

Using No. 28 enamel wire, and a diameter of 1¼ inches, the antenna coil consisted of 15 turns for the primary, ¼-inch space, and 96 turns for the secondary. The others had 25-turn primary, 70-turn secondary, ⅜-inch separation.

The shields are 3½ inches high, so the winding form should not be more than 3¼ inches high. This space is enough to accommodate the large coil, which has a total of 111 turns, i.e., 15-turn primary and 96-turn secondary.

The coils should not be placed very close together, even though they are shielded. The idea that there can be no inductive coupling between shielded stages is erroneous. If the coils are so arranged that the shields are separated only a slight distance, say ⅛ inch, there will be plenty of coupling, also considerable squealing. But if the coils are placed with shield walls at least one inch apart, there will be no such trouble from inductive coupling.

## and Remove Hum

search coil at various points close to the core, or over the sheathing that covers the core of the output transformer. At some point the hum will be heard that is similar to that of the speaker output. Now if the search coil is held in the same position relative to the core, and moved away from it at the same time, the intensity of the hum will subside but it will still be audible and the chances are that the path thus traced will lead to the other transformer.

Close grouping of transformers that are not well shielded magnetically is especially troublesome in push-pull amplifiers, and if it is not possible to alter the placement of the apparatus the alternative method of suppressing the distortion is to couple the plate of the amplifier tube to the P terminal of the audio transformer with a fixed condenser of say 1 mfd., and supply the plate potential through a series choke, which may be the secondary of an old 1-to-3 audio transformer. This method of coupling removes the DC from the coupling transformer primary.



# Single Tuning Control

By Henry

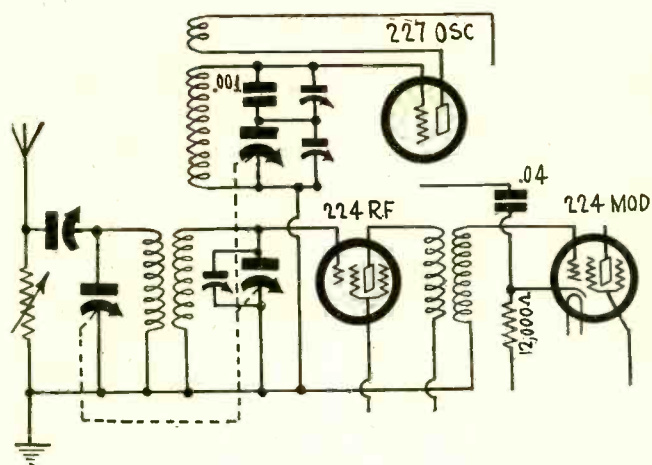

Fig. 1

Skeleton diagram of the radio amplifier and mixer circuit of the Majestic Model 50, one of this season's commercial Superheterodynes. The oscillator circuit (upper) has series and parallel capacity.

WHEN single tuning control began to become popular in tuned radio frequency receivers in 1925, some technicians doubted the electrical advisability of resorting to this admitted convenience, pointing out that it is not possible to have multiple tuned circuits flawlessly synchronized by the gang method. Although separate controls produced an awkward appearance and made tuning a multifarious operation, they afforded better selectivity and sensitivity, for each circuit could be perfectly resonated.

What have these gentlemen to say today on the subject of gang tuning of the oscillator and the modulator of a Superheterodyne for broadcast frequency reception? The problem is much more difficult.

## Intermediate Frequency Values

In the example of a tuned radio frequency receiver, each circuit is to tune through the same band of frequencies, 1,500 to 550 kc. In a Superheterodyne the modulator and radio frequency amplifier, if used, tune the same way and to the same purpose as the familiar tuned radio frequency receiver, but with the oscillator the frequency problem is different. In fact, only the difference between the oscillator tuning, and the modulator and radio frequency tuning, produces the admixture frequency which is known as the intermediate frequency, and thus only the difference makes Superheterodyne reception possible.

How great the difference will be will depend on what the intermediate frequency is. The lower the intermediate frequency, the smaller the difference between the locally generated oscillator frequency and the frequency of the original carrier, or station to be heard. Hence the higher the intermediate frequency, the greater the disparity of the dial settings, if one assumes for the moment that the oscillator is independently tuned, and that the same constants are used in both circuits.

The commercial receivers tend to favor an intermediate frequency of 175 kc, or a little less than 1,715 meters, which may be regarded as a medium intermediate frequency, particularly as around 70 kc was used in kit-sets only a few years ago.

## Capacities Offer Solution

Assuming that the difference in frequency between oscillator and modulator is to be established by using the higher oscillator frequency, it is obvious that while the modulator is to tune from 1,500 to 550 kc, the oscillator must tune from 1,675 kc to 725 kc. Mere use of the same capacity tuning condenser in the oscillator circuit, and a smaller inductance in the same circuit than in the modulator, will not solve the problem, because the extremely narrow range of frequency needed for oscillator tuning would be grossly exceeded. Nor would use of the same coil, but with a smaller capacity for tuning, constitute the solution, for the ratio of the condenser would be far too high.

But the problem can be solved by resort both to reduction of the maximum capacity and increase of the minimum, as well, either using an equal inductance or a smaller inductance. The

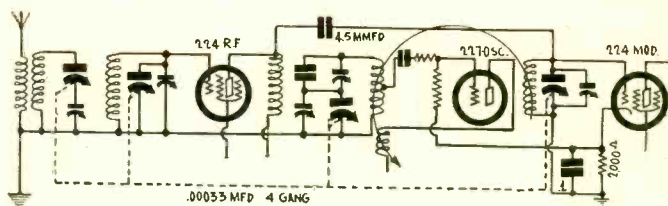

Fig. 2

The radio amplifier and mixer of the new Radiola Superheterodynes, Models 80 and 82, in basic sketch form. The same system of series and parallel capacity is used in the oscillator to gain conformity tuning. Here a four-gang condenser is used, whereas Majestic uses a three-gang.

high minimum capacity confers on the condenser a band-spanning characteristic, of the nature familiar to amateurs, who desire only a narrow band of frequencies to be tuned in over the entire spread of a dial.

## Series and Parallel Capacities

As examples of this method, the essentials of the radio frequency and mixer circuits of the Majestic Model 50 and the Radiola Models 80 and 82 are shown in Figs. 1 and 2. The Majestic 50 is the consolette model Superheterodyne introduced this season, while the Radiolas, 80 and 82, are identical to each other, except that the 82 is equipped with tone control.

In both the Majestic and Radiola instances there are a radio tuned radio frequency stage, using a 224 tube, a 224 modulator and a 227 oscillator. It is interesting to note that the Majestic has a 12,000 ohm biasing resistor in the modulator cathode lead, while the Radiolas have a 2,000-ohm value. Modulation results in either instance, but the tubes are worked at different points on their characteristic curve.

## Only One Is a Control

In the oscillator circuit in both instances there is a section of the gang condenser. The first point to notice is that a series condenser is connected from stator of the tuning condenser to the grid connection of the tuning coil. This reduces the effective capacity of the tuning condenser. Across this series condenser (.001 mfd. in the instance of the Majestic and .000745 mfd. in the instance of the Radiolas) is an adjustable parallel capacity. Thus the effective series capacity may be adjusted. The fourth condenser in the oscillator tuning circuit is a trimmer across the section of the gang, so that the minimum capacity may be raised.

The fact that there are three variables does not mean there are three controls for the oscillator circuit, since the object of introducing variables is to make for fine sensitivity and selectivity in preparing receivers for dissemination, while the gang remains the control for the user.

The attainment of the two extreme values, or equivalents, for both circuits may be said to constitute the solution, since hardly any means remains for improving on this, unless a condenser with specially shaped plates, or in which the shape of the plates may be altered due to slotting, is available. Thus the extremes need not be disturbed, while the capacities at settings between these may be permanently altered.

## The First Step

The method generally employed in achieving successful synchronization of such tentatively dissimilar circuits as modulator and oscillator is to get a tuning curve, or dial settings, for the tuned radio frequency portion and modulator, these affording the same curve, and note the extreme points, or other particular points, e.g., where 1,500 kc and 550 kc come in. Suppose the readings are 3 and 97. Then with an independent tuning condenser across a test oscillator, which may be one section of another gang condenser from the same lot, with modulator set for 550 kc, the oscillator, too, is set at 93 dial reading, and a variable series condenser is adjusted until the signal comes through strongest. The oscillator is tuned and a curve is run. Comparing the two curves, the fixed one for the modulator and the experimental one for the oscillator, it will be found, perhaps, that the oscillator brings in 1,500 kc at 40 on the dial. Therefore the series capacity is reduced, and a parallel capacity is placed across the tuning condenser, while another attempt is made,



# in a Superheterodyne

B. Herman

again starting at 550 kc. The oscillator may be found to be off still.

Thus it is always simple to get "one end," but the other proves elusive. It is not necessary at first to do more than to get the extremes, so that the oscillator will tune in 550 kc at 93 and 1,500 kc at 3. but the work of tying down both ends sometimes proves a long but not uninteresting job. Finally, when they are tied down, the two curves, modulator and oscillator, will be found to vary. Some attempt to get coincidence at other dial points, or frequency settings, than the extremes. This can amount to little more than perfecting or improving resonance by trimmer adjustments on modulator and pre-tuner circuits, since if the two ends have been tied down correctly for the oscillator, any disturbance of the constants would destroy the balance already achieved.

## Getting the TRF Signals Through

In the mixer circuits diagrammed you have a stage of tuned radio frequency amplification and modulator, both circuits tuned. so with the oscillator tube out, you can hear broadcast stations directly, by putting earphones in series with the modulator plate circuit. In this way you can get the modulator dial settings, particularly the extremes, which are desirable.

If the extremes are not used, some other frequencies, not far removed may be utilized. For instance, for 175 kc, one may use as the higher settings, 1,400 kc, particularly since 1,400 kc is the eighth harmonic of 175 kc. The other extreme may be 600 kc. These examples are cited because they are the ones said to be used by the Radio Corporation of America in tying down the two points for the 80 and 82.

If you desire to experiment with the Superheterodyne circuit, you should calibrate the tuned radio frequency portion of the system, which includes the modulator, and thus be able to select two extreme or equivalent points for oscillator guidance. You may even use broadcasting station frequencies as guides, so that what the two frequencies shall be may depend on what stations, in the desired frequency regions, are readily tuned in. In a stationery store you can buy a few sheets of graph paper, and it is well to run a curve, plotting frequency against dial settings, starting with the two extreme frequencies with the full curve of tuned radio frequency system, using six points or more, but particularly noting the two far-removed test points against which checking is to be done.

## Choice of Intermediate Frequency

The next step, for present purposes, is to set up the intermediate frequency amplifier. It does not matter what its frequency is, so far as the test goes. If you are at a loss to provide yourself with an intermediate channel, you may use the lowest frequency setting of a broadcast receiver, affording an intermediate frequency of, say, 530 kc, or you may take regular broadcast coils and, using two of them, with a fixed condenser across the secondary twice as large as the capacity tuning condenser they require, and adding a trimming capacity, do your testing on this basis. Your task will be the harder because of the high intermediate frequency, since the oscillator and modulator tuning always must differ by the intermediate frequency, which in this case may be 400 kc or so.

As you may have only a single gang condenser, with no equal tuning capacity for independent control of oscillator, you may temporarily disconnect the stator of the modulator condenser from the coil to which it was attached, and introduce the aerial into the oscillator grid through a small fixed condenser (.0001 mfd. or less) or by putting a few turns of wire around the modulator grid winding, and connecting aerial to one end of this winding, the other end of which may be left free or be returned to ground.

Now all the frequency discrimination will arise from the rotation of the section of the gang across the oscillator grid coil. The one extreme point may be selected for test, the dial being put at the same numerical setting as prevailed for modulator tuning. Then the series condenser, which should be variable, is adjusted, also the parallel capacity across it, and even the trimmer across the section of the gang. After the one point is attained, which is easy, the other is sought, which is not so easy.

## Capacity Is the Main Consideration

The inductance may be the same for the oscillator secondary as for the modulator secondary, or it may be less, although the problem is essentially one of capacity adjustment, and difference in inductance has a relatively small effect in simplifying the solution.

In making the tests, it is well to remember that slight reduction in series capacity shows up as a large effect on the main

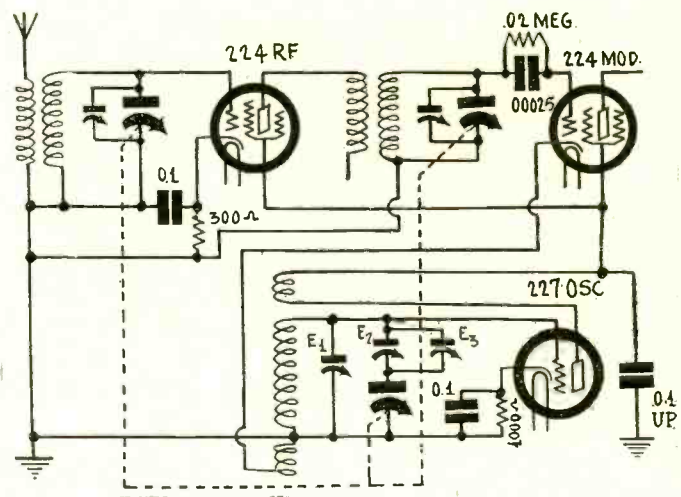

Fig. 3

An excellent mixer that may be used by the home experimenter in tying down two far-removed tuning points of the oscillator to establish coincidence of dial settings with those of the radio amplifier and modulator.

capacity (which is the tuning condenser), and that when the band of frequencies that you desire to spread over the entire dial is encompassed by a small part of the dial, that the extra capacity across the tuning condenser should be increased. With these two ideas well in mind, the rest of the cut-and-try method work may be done, until finally you will have a single control mixer that will work with the intermediate frequency amplifier of your choice. The work has to be done all over again for any other intermediate frequency.

When the two extremes are found at the same positions on the oscillator dial as they were on the modulator dial, it is interesting to run a curve, and note whether there is any divergence between the two curves, and particularly where it is greatest. This visual comparison of curves will forecast accurately the regions of greatest and least sensitivity, since where the curves are identical sensitivity and selectivity are utmost, and where they depart the most these attributes are at a minimum. However, divergences need not provoke any great concern, as there is no simple way to avoid them (if there is any at all, without resorting to manually-operated trimmers), and there is no danger of prevention of reception. There will be only some unevenness of sensitivity and selectivity through the broadcast band of frequencies.

## Make the Intermediate Resonant

There is another consideration respecting sensitivity and selectivity, and that is the intermediate amplifier. It is relatively easy to resonate the circuits of this amplifier, since independently accessible trimmers are across each tuned winding, if the foregoing suggestions were followed, or an intermediate train of transformers is used that has been tested on an oscillator at a factory that produces such couplers.

By all means see to it that the tuning is carefully done in the intermediate channel, as mistuning here, as well as anywhere else, has a marked effect in reducing both sensitivity and selectivity.

The circuit shown in complete form in Fig. 3 may be used for the mixer, the coupling coil consisting of a few turns, say 8, as a continuation of the grid winding of the oscillator.

## New Set Builder's Guide

For those many fans desirous of constructing such receivers and amplifiers that afford the utmost in efficiency, three manufacturers have united to issue a 24-page booklet, "The Set Builder's Guide of Outstanding Circuits."

The publishing of this educational booklet was made possible by The Hammarlund Manufacturing Company, Inc., Amperite Corporation, and Electrad, Inc. The text was compiled and edited by Harry G. Cisin. A special table of symbols of radio components, pictorially described, is a feature of the manual.



# The Philco Transitone

## 1931 Models Include Improved Hookup

**Fig. 1 (at right)**  
 The circuit diagram of the Philco-Transitone Automobile Radio Receiver. It contains an automatic volume control for eliminating the fading due to changes in field intensity as the car moves.

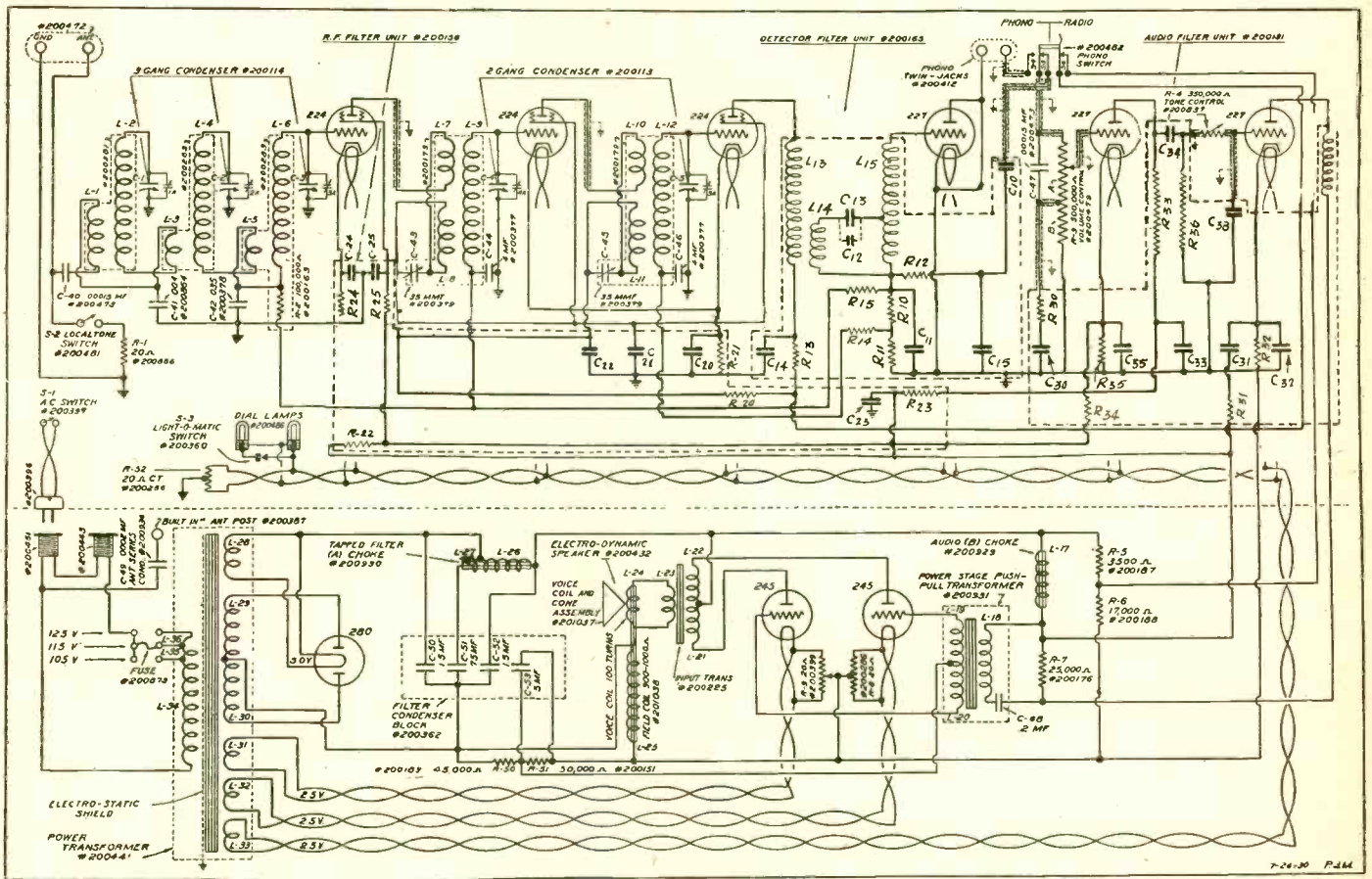
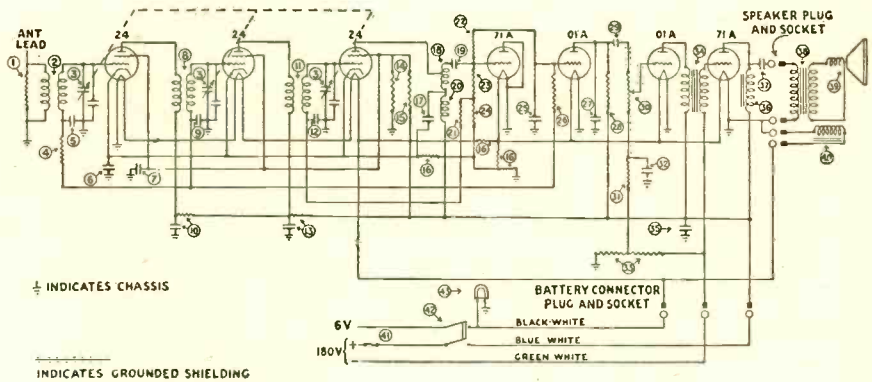

**Fig. 2**  
 Diagram of the Edison screen grid radio receivers, Models R-6 and R-7.

**T**HE Philco-Transitone Automobile Radio Model No. 3, shown in Fig. 1, is a seven-tube receiver incorporating three 224 screen grid tubes as radio frequency amplifiers, two 171A type, one used as detector and one as power tube, and two 201A, used as audio frequency amplifiers. The heaters of the three 224 tubes are connected in series across the storage battery of the car, and therefore each tube is operated at 2 volts. The filaments of the 5-volt tubes are connected in parallel across the battery, except that a common ballast resistor of one ohm is used in the positive lead to cut the voltage to 5 volts.

The 171A detector is connected as a diode, the plate and the filament being connected together, and it is also used as an automatic volume control. This automatic control feature is obtained by returning the grids of the radio frequency amplifiers to various positions on the output resistance of the detector

tube. It will be observed that the grids of the first two tubes are returned through a high resistance (25) to the grid of the first audio amplifier tube while that of the third tube is returned to a point on the resistance (23, 24). Since the grid of the detector tube is the lowest potential point available, if the cathodes of radio frequency tubes are connected to any other point the bias on the amplifiers will be negative and the amount by which they are negative will vary with the intensity of the signal on the detector. Hence there is a continuous check on the amplification and the volume is automatically held at a nearly constant level.

### Manual Volume Control

The cathodes of the three RF tubes are connected together and finally are joined to the detector output circuit at a point



# and Crosley Midgets

## ps and Assurance of High Sensitivity

which is positive with respect to the point at which the grid returns are made.

A manual volume control in the form of a high resistance potentiometer (28) is connected in the grid circuit of the second audio tube, the slider being connected to the grid of that tube. Thus the volume may be set at any desired level and the automatic feature will then hold it at that level.

The receiver is equipped with an electro-dynamic speaker which has been designed especially for automobile receivers. It has a field coil designed for operation on a 6-volt source and it is connected across the storage battery of the car in shunt with the tube filaments.

The output circuit of the power tube is designed so that the feedback is a minimum. That is, a choke is used for feeding the plates and the primary of the output transformer is connected in series with a condenser from the plate to the negative side of the filament battery. The choke prevents audio frequency currents from entering the B battery and the current that flows through the primary is led directly to the filament of the tube, thus avoiding the B battery. This wiring is of considerable importance in all receivers and it is especially important where resistance coupling is used in whole or in part.

### Obtaining Fixed Bias

Bias voltage for the grids of the amplifiers is obtained from the B battery by arranging the circuit so that the negative of the B battery is at a lower potential than the negative of the filament battery. In effect, grid bias resistors are used although the tubes involved are of the battery type.

The applied plate voltage is the same on all the tubes, namely 180 volts, except that resistances are placed in series with the plate leads of the first two tubes. These are used more for the purpose of stabilizing the circuit than to reduce the voltage. Condensers are used to aid in the stabilization. The screen voltage on the first three tubes is also the same, being equal to the voltage drop in a resistance (14). This voltage is reduced from the plate voltage by the drop in (15), which connects to the 180 volt lead.

Each tuned circuit consists of a tuning condenser with a trim-

stations, and it may even be called on to receive when shielded by metal structures of large dimensions. Moreover; it must be designed so that under continually changing conditions the signals must remain constant in intensity. This is the function of the automatic volume control and this must have a much wider range in an automobile receiver than in a receiver installed permanently in a fixed location.

Another feature possessed by this receiver, and one that is absolutely necessary, is simplicity of tuning. There is only one control for the three tuned circuits.

### Edison Screen Grid Receivers Models R-6 and R-7

Fig. 2 is a complete diagram of Edison Models R-6 and R-7 screen grid radio receivers. This has five tuned circuits, three of which are in front of the first tube, and therefore there is ample selection ahead of that tube to prevent cross modulation. It will be noted that the two interstage couplers contain circuits tuned to a frequency a little lower than the lowest broadcast frequency to boost the sensitivity at the low frequency end of the scale. The tuning condenser in each case is connected so that the higher frequencies are by-passed around the large inductance across which it is connected. This prevents choking out of the higher frequencies by the coil.

The detector is of the high voltage type, using a 227 type tube feeding into a resistance coupler, but connected as a two-element tube. There is a second 227 tube audio frequency amplifier coupled to the first by means of a resistance coupler.

The volume control is combined with the grid leak ahead of the first audio amplifier and is a 500,000 ohm potentiometer to the slider of which the grid of the succeeding tube is connected. A tone control is wired into the grid circuit of the second audio tube and this consists of a 350,000 ohm variable resistor connected in series with the line to the grid. A condenser is connected from the grid to the ground.

The power stage contains two 245 tubes in push-pull. A special feature in this stage is that each tube is served by a separate filament winding on the power transformer with a separate 20 ohm potentiometer across each filament for balancing out the hum. Thus the hum may be balanced in each tube independently

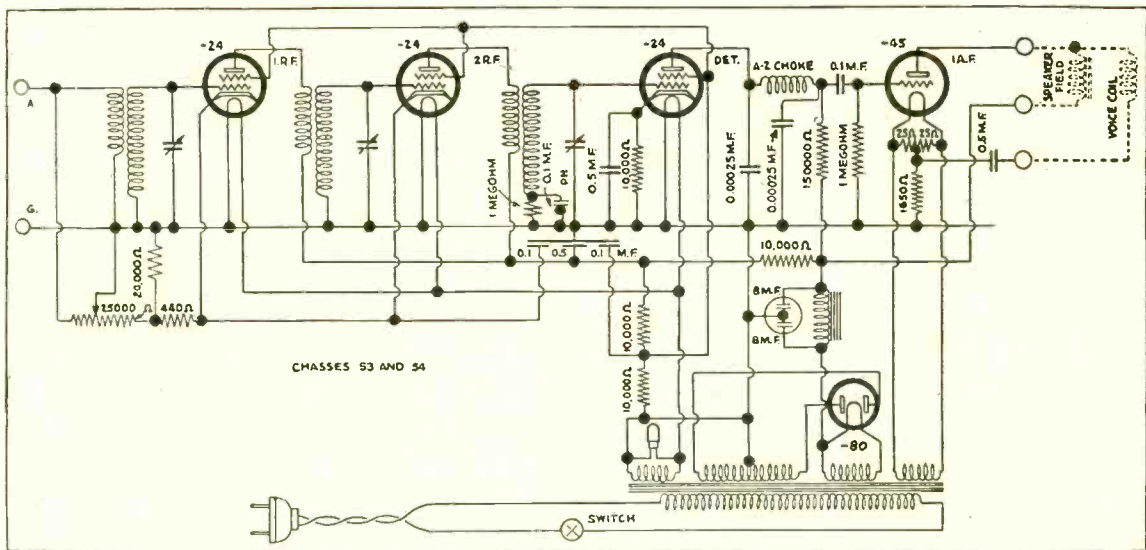

Fig. 3

This is the circuit diagram of the Crosley Models 53 and 54 Midget receivers. With a few minor exceptions it is also the diagram of Model 57.

mer in shunt, a tuning coil, and a large condenser in series. This condenser serves several purposes. First it completes the tuned circuit; second, it permits grounding of the tuning condenser rotors and at the same time returning the grids to the proper negative voltages; third, it acts as a filter of the voltage fed back from the detector for the purpose of the automatic volume control. This filtering is necessary for without it there would either be oscillation at radio frequency or the sensitivity of the receiver would be cut down.

### Great Sensitivity

The sensitivity is high, as it must be to insure reception under all conditions that will be met in a car. The set may be called on to deliver signals at long distances from any broadcast station, in places shielded by hills, mountains, and woods from

of the other. This, of course, aids in eliminating hum, since it permits adjustment for slight differences between the two tubes.

### The B Supply Filter

Next to the rectifier is a 1.5 mfd. condenser across the line of the B supply circuit. Then follows a resonant shunt across the line consisting of an inductance L27 and a .75 mfd. condenser. The values of inductance and capacity are so chosen that this circuit forms a shunt of practically no impedance at the hum frequency, thus preventing hum from being transmitted. The placement of L27 on the core of the main choke coil L26 also helps to buck out hum.

The field coil of the dynamic speaker is really in series with the B supply line, thus acting as a choke, but it is placed in the

(Continued on next page)



# Excitement as Con'

By Herman

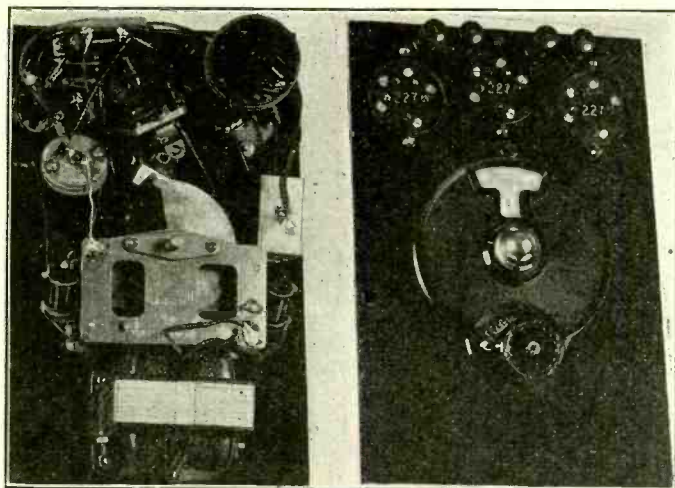

Fig. 1

Views of the wired model of a converter on a 6 x 9-inch panel, and in the \$15 class. Filament transformer is included, as well as National Velvet Vernier dial

**T**HE short wave converters that have been described in these columns, beginning with the November 8th issue, and continuing each week since then, have been principally as follows:

(1)—A three-tube converter, using 227 tubes, both in AC and battery-operated forms. The battery model used the 227 heaters in series across a 6-volt storage battery. A fixed coil was used, and one tuned circuit. Filament transformer, if used, is external. The wave range is 30 to 110 meters.

(2)—A three-tube AC model, using 227 tubes, with filament transformer and switch built in, and using plug-in coils for wider wave range, that is, 15 to 600 meters, so even the broadcast band can be tuned in. One tuned circuit is used.

(3)—A three-tube AC model, using screen grid tubes throughout, and plug-in coils, to cover from 15-600 meters, with two tuned circuits for the broadcast band, at least, with option of one or two tuned circuits for short waves, depending on coils plugged in

## A Larger Model of First Converter

The model mentioned under (1) was built on a 5x6½-inch panel that fits into a wooden cabinet. Using a somewhat larger panel, 6x9 inches, room is provided for the filament transformer. How the larger sized layout appears is shown in Fig. 1, while the diagram of this is printed as Fig. 2. It is the same diagram as used for the smaller model, except for filament transformer added, but as there is not much doing above 80 meters, it was considered advisable to make the coil of lesser inductance, to tune from about 20 to 81 meters, with the .00035 mfd. condenser used. The winding data for this is as follows: On a tubing 1¾ inches in diameter, using No. 24 silk covered wire, wind six turns for the secondary, tap, and wind one more turn for pickup. Leave ⅛ inch space and wind 12 turns for the tickler. The connections, top to bottom, are: beginning of the secondary winding to grid of the oscillator tube, tap to ground, end of single-turn winding to cathode of the modulator, beginning of tickler (adjoining end of other coil) to B plus, and remaining tickler terminal to plate of the oscillator. The B plus voltage should be 50 volts or more, while even up to 180 volts may be used. This voltage you must obtain from the receiver with which the converter is worked.

Data on the de luxe triple-screen grid model were published recently. The diagram is printed herewith as Fig. 3, some slight changes having been introduced. These changes consist of a different method of obtaining the screen voltage and in the introduction of grid leak-condenser modulation, as many readers have requested this form of modulation. It is more sensitive than the negative bias method of modulation, but overloads more quickly, as was explained when the optional modulation schemes were first presented, but readers seem to prefer the overload danger, because at all hazards more stations can be tuned in by the leak-condenser method. However, the pickup winding should be of smaller inductance in this case, to help prevent too early overload of the modulator. Two turns are enough, with a 13-turn secondary, and four turns with a 23-turn

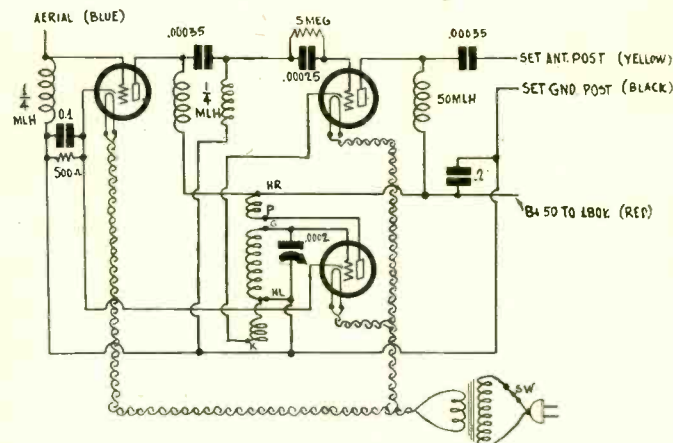

Fig. 2

The circuit diagram of the converter shown in Fig. 1.

secondary, on tube base plug-in forms. Precision coils may be used, also. Notice that with the screen grid tube as modulator where short waves are concerned a much lower value of grid leak is used than is otherwise recommended, that is, 20,000 ohms instead of several million ohms.

The screen grid tube as an oscillator produces a steadier voltage than does the 227, and also the method of obtaining the screen voltage for all three tubes makes the screen current

## Intimate Details of

(Continued from preceding page)

negative side across a total resistance of 95,000 ohms. Since the field coil itself has a resistance of the order of only 1,000 ohms most of the current flows through it and the 95,000 ohm resistance serves mainly to prevent an open in case the field coil should be disconnected or become open. The 95,000 ohm resistance is divided into one 50,000 and one 45,000 ohm sections and the higher of these is used for grid bias on the two power tubes. The voltage drop in the field coil would give too high bias to the power tubes, and this is another reason for using the 95,000 ohms, that is, to permit the use of only part of the drop in the coil for bias.

The primary of the power transformer is tapped for 105, 115 and 125 volts, and the proper tap is selected by putting the line fuse in the appropriate clips. An electric shield is placed between the primary and the various secondaries to prevent line disturbances from entering the receiver by way of the capacity between the windings.

Provision is made for a phonograph pickup unit and it is connected in the plate circuit of the detector, or more accurately, in series with the grid leak or volume control potentiometer ahead of the first audio frequency amplifier. The detector cannot be said to have a plate circuit since the plate and the cathode are connected together. The unit is connected so that the potentiometer can be used for controlling the volume of the phonograph music as well as that of the radio receiver.

In tracing out the grid returns of the three screen grid tubes as well as the cathode leads of these tubes we note that the effective grid bias changes with the intensity of the signal because a part of the detector output is included in the grid circuits. Thus there is an automatic volume control effect without using an extra tube for this purpose.

Midget radio receivers are almost as popular at this time as electric clocks, and nearly all radio set manufacturers are making them. In Fig 3 herewith we are presenting a circuit diagram of Crosley Models 53 and 54 Midgets, and this with a few minor changes is also the diagram of Model 57.

Although this diagram is simple and contains five tubes, including the rectifier, it contains all the necessary elements for simplicity of control, sensitivity, selectivity, and high undistorted output. It has three tuned circuits to insure selectivity, two screen grid radio frequency amplifiers and a screen grid power detector to insure sensitivity, and a 245 power amplifier with a dynamic speaker to insure a high undistorted output.

The circuit is provided with a manual volume control, which takes the form of a 25,000 ohm rheostat across the antenna coil. The control is double-action because as the rheostat slider is moved in the direction of stronger signals not only is the resistance across the antenna coil increased but the grid bias



# Converters Get Europe

Bernard

through the limiting resistor change in step with the plate current, which likewise tends towards steadiness, and helps remove some of the fading effects on short waves. In many instances these effects must be due to the "floppiness" of the oscillator.

All of these converters work well. It has been a pleasant surprise to fans who had sad experiences with short-wave adapters that plug into the detector socket, and like as not produced no signals, to find a device that converts a receiver into a Superheterodyne, or that works with a receiver that already is a Superheterodyne, and that really does bring in the stations.

Quite a few of the builders have brought in European and South American stations, as well as having heard from Canada and virtually all parts of the United States, so there must be something to these converters. At least they are very easy to tune, not nearly so much skill being required as with the regenerative short-wave set or adapter, and even boys of 15 years of age have brought in foreign stations without previous instruction, using sets that are only fair. There was much excitement in homes as Europe was heard directly on converters.

The performance depends mostly on the receiver with which the converter is worked.

If no signals at all are heard there is either a short or an open circuit, in part or in toto, a bad tube, which amounts to the same thing, or a misconnection either in or outside the set converter to the set, which also means short or open circuit. An improper load on a tube is also a part short circuit, but the proper loads were described in the series of articles, and for the present purpose also are imprinted on the diagrams.

One of the fine attractions of the converter is that it does work even on the highest frequencies to which the circuit can

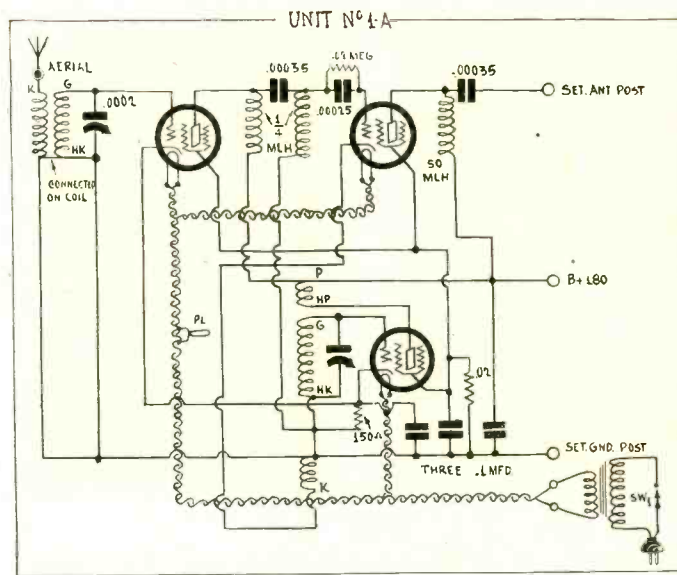

Fig. 3  
Design of a triple-screen grid converter, 15 to 600 meters, with leak-condenser modulation and a steadied screen voltage effect.

## the Crosley Midgets

resistance is decreased so that when the entire 25,000 ohms is across the antenna the 20,000 ohm bias resistor is shorted, leaving only 440 ohms for biasing the two screen grid amplifiers.

Provision is also made for a phonograph pickup unit. In the third tuned circuit is a one megohm resistance in series with the coil. Across this resistance is a condenser and binding posts for the pickup unit. The receiver comes with the binding posts short-circuited. If a pickup unit is to be connected this short-circuit is to be cut and the unit connected. By means of a double pole, double throw switch, not built in, the pickup unit may either be cut in parallel with the one megohm resistor or a short-circuit across it may be connected. Since the switch will be on the low potential side of the circuit it will not affect the tuning characteristic of the receiver.

There is only one audio frequency amplifier, and for that reason the screen grid detector must operate on the high signal principle. The bias for this tube is obtained from a 10,000 ohm resistor placed in the cathode lead.

The output circuit is quite ingenious and is very suitable for a midget set. The field coil serves as plate impedance of the power tube in addition to its normal function. Thus the plate current of the power tube is utilized to establish the field in the speaker. Another feature is that the voice coil, which is wound to fit the tube without a coupling transformer, is connected directly between the plate and the cathode of the tube, through a 0.5 mfd. condenser. By cathode here is meant the center of the filament circuit. It will be observed the filament circuit is balanced by means of two 25 ohm resistances, one on each side of the voice coil return.

A bias resistor of 1,650 ohms is connected from the junction of these two resistors and bound to maintain the grid of the tube at the proper negative potential. There is no by-pass condenser across this resistor, but the return of the voice coil to the cathode and the thorough filtering in the B supply make it unnecessary to use one. The filtering is secured by one choke and two 8 mfd. electrolytic condensers.

The coupling between the detector and the audio amplifier is by means of resistance. The plate resistance is 150,000 ohms while the grid leak is one megohm. A 0.1 mfd. condenser is used for blocking. There is also a low-pass filter between the plate of the detector and the resistance coupler, and this consists of a radio frequency choke in series and two .00025 mfd. condensers.

Models 53 and 54 are practically alike, differing only in mechanical construction. Model 54 is smaller and more compact and is intended for small cabinets of the mantle type. Models 53 and 57 are similar except that a few circuit changes have been introduced.

be tuned. Usually in short-wave sets there is difficulty obtaining oscillation at these frequencies. The use of low inductance RF choke coils, with consequent slight distributed capacity, accounts in part for this good response at the high end.

But it should be borne in mind that frequencies around the 20-meter band, and higher in frequency, are not received well in the night-time as they are by day. This is one of the phenomena associated with this band and has nothing much to do with the reception device used, although with converters the reduction in response in this precious band is much less than with straight short-wave sets, since most of the amplification is at an intermediate frequency, that is, 1,500 kc or lower, that being the frequency to which the set is tuned.

About the most important asset, aside from the receiver or converter, getting your money's worth out of short waves, is to have an up-to-date list of short-wave stations. This list should include both foreign and domestic stations and should state when these stations are on the air.

From time to time in these columns such a list has been printed, but work is being done on a new list, which ought to be ready for publication in a few weeks, and which will give, for the first time, all the essential information: wavelength, frequency, call letter, location, and hours on the air, in Atlantic Standard Time, Eastern Standard Time, Central Standard Time, Mountain Standard Time and Pacific Standard Time. The Atlantic time is for the benefit of the Canadian customers who have this time. Each classification will be complete and will be duplicated with only the time change. Thus you would not have to accept the statement that a station is one the air at 2 o'clock Greenwich Meridian Time, which requires not only conversion to our own system (easy enough) but also allowance for the time difference between the foreign, and even domestic stations, and your place of abode. For territorial United States the time differences are well known, but who knows offhand the difference in time between New York and Siam, or between Denver and Guadalupe or between San Francisco and Motala, Sweden? Not I.

### Worth Getting Into

Those who have not had any experience with short waves are cordially invited to get into the swim, as the fun is great. Also, the expense need not be killing. The model mentioned under subdivision (1) was designed so that it could be built of parts costing less than \$5 (not including filament transformer, about \$2.50 extra), while the model mentioned under (2) was designed so that \$10 would cover all parts, including filament transformer, and model (3) is in the under-\$20 class. The enlarged model of (1), as illustrated, is in the \$15 class, due to precision deal and the Polo filament transformer.



# What Short Waves Offer

By Brainard Foote

**T**HE rapidly growing use of short waves for broadcasting and television, in addition to the enormous use of short waves for code communications by radio amateurs, governmental and commercial interests, makes short-wave radio reception of more popular interest than ever.

As popularly understood, short waves are those waves shorter than 200 meters. Regular broadcasting uses waves from 200 meters up to 545 meters. Expressed in kilocycles, this band is from 1,500 to 550 kc, or a stretch of about 950 kc. A space of 10 kc is allowed between stations to avoid interference, so we can have less than 100 broadcasting stations within range of each other to avoid interference, operating at the same time.

## Wider Span on Short Waves

Short waves present a striking contrast. Reaching from about 20 meters to 200 meters, we have a range from about 15,000 kc to about 1,500 kc, or a span of about 13,500 kc. Allowing 10 kc per station, we have "room" for at least 1,350 stations all at once! However, upto 100 kc separation is allowed on some short waves, and in one instance 1,000 kc. For the numerous sections of the short-wave band that are reserved for code messages, the stations may be closer together than even 10 kc, so that really many thousands are able to operate side by side.

Here are the principal facts about short waves in which you will be especially interested: Skipping, fading, methods of reception.

It is a most peculiar and interesting fact that short waves seem to rise from the ground abruptly, and then return to earth at long distances away. Accordingly, you will find that you may be unable to receive a short wave station nearby, whereas you will get very fine reception from stations hundreds, or even thousands of miles away! This is surely a convenient thing for long-distance work, isn't it?

Fading is more or less prevalent, on the longer wavelengths particularly, but at certain times, and on certain waves, great steadiness is maintained. Certain waves are particularly desirable for long distance work during the daytime.

Static interference averages less than on broadcast wavelengths of 200 meters and higher, although on waves as short as 5 or 10 meters, occasionally used now, we find some interference caused by electrical sources, particularly automobile ignition systems.

## Waves for Short-Wave Broadcasting

The wavelengths generally employed for broadcasting the regular programs are about 50, 30, 25, 20, 16, 14 meters. In daylight, waves near 20 meters carry very well. Waves near 40 meters work out well or both night and daytime work, being better at night.

The wavelengths generally used require such a wide change in the tuning of the radio set that specially designed sets are used. The regular broadcast set, from 200 to 500 meters, covers only about 1,000 kc from top to bottom. Accordingly, one coil and one tuning condenser serve well for tuning each stage. On short waves we have about 30 or 50 times this spread of frequencies, and a single coil and condenser do not begin to serve the purpose.

Hence, the best short-wave sets utilize an assortment of coils

of different inductance, and the desired size may be inserted in special coil sockets very quickly. One tuning condenser is thus made to serve for all the different sections of the short-wave band. Without the interchangeable coils, the set would have to be designed to fit a certain smaller portion.

## Circuits Used for Short Waves

A good battery-operated system to use is a 3-tube set with a 200A or 201A type detector tube and two stages of audio frequency amplification. The detector is connected in a regenerative circuit. The elaborate receiving systems used for ordinary broadcasting are not necessary for short-wave reception, nor are they always possible to use because of circuit difficulties.

A considerably better system is to employ a 222 or 232 screen-grid tube for a radio frequency amplifier, using a regenerative detector and two stages of audio frequency. It will be found simple to use a storage battery type set for home use and experimentation.

The alternating current short-wave sets are not so easy to design, because of the numerous points in the circuits where the alternating current may cause hum. There are, however, several commercial A C short-wave sets that are very good indeed and to be relied upon, as well as some fine kit-sets.

For the listener who does not wish to have a special set for short-wave reception there are several makes of adapters on the market. These are so built as to be responsive to short waves and use the regular audio amplifying and loud speaker sections of your regular set. The adapter set has a cord and special adapter plug which is inserted in the detector socket of the regular set. The regular detector tube that was removed from the set socket goes into the adapter socket. This corresponds to the first short wave set mentioned above, but this type of adapter is not very reliable, because regeneration may fail, due to necessity for accepting the receiver detector load and plate voltage "as is."

## Converters Are Popular

Recently short-wave converters have become very popular, as they are dependable. They constitute radio frequency amplifier and Superheterodyne mixer for short-wave reception. Thus they change the short waves to an intermediate frequency that the set can utilize, and besides, work with the entire set, which the so-called "adapters" don't do.

Considerable skill is required to operate the short-wave set successfully, because the adjustments are extremely critical and delicate. Once the knack is acquired, however, phenomenal results may be obtained, and you can often hear broadcasts from across the oceans. Tuning a converter, however, is far easier, as there is no regenerative control.

A good list of short-wave stations is essential, and a new one should be obtained frequently, because rapid developments in this field are bringing fast changes.

You should also use a time chart giving international time, so that you will know when to listen for the different stations according to your own local time.

Short waves present a radio field that is highly fascinating, and will prove a mine of interesting surprises to the listener.

# Methods of Levelling Amplification

**O**NE of the greatest difficulties with the broadcast receiving set is its failure to amplify the various wavelengths equally.

If the set is adjusted by the manufacturer to amplify very effectively on the lower waves, just above 200 meters, it falls down when it comes to stations near the upper waves, near 400 meters and over. Yet, if it is made very sensitive on the longer waves of 400 or more meters, it will oscillate on low waves, causing poor tuning, whistles, etc.

The more expensive recent radio models utilize a number of systems designed to obtain a more uniform amplification on the various wavelengths. If this is accomplished solely through the volume control, as with many sets, the volume control becomes very critical and must be adjusted all over again whenever the set is changed to a different wave.

Automatic systems are in vogue which eliminate this trouble. In one system the small primary coil is moved farther away from the secondary coil as the shorter waves are approached, thereby

maintaining a much more uniform tuning relationship by mechanical means. In another similar system, the primary coil is moved at an angle so as to provide closer coupling where it is needed for the longer waves. Still another system, a small section of the primary coil is wound on a rotating coil in such a way that at low waves this is reversed, thus subtracting from the normal coupling. At longer waves, the coil turns around, thus adding its effect to the rest of the primary.

Still another system utilizes both inductive coupling and capacitive coupling. One form of coupling provides a greater effect on long waves, and the other form on short waves, so that by proper juggling of the values of both, a very uniform condition is achieved. The disadvantage of this system is its difficulty in manufacture, so that it is of principal interest to experimenters only.

A fairly even response may be gained by using one untuned stage, broadly peaked at around 400 meters or more.



# Adjustments for Push-Pull

By Einar Andrews

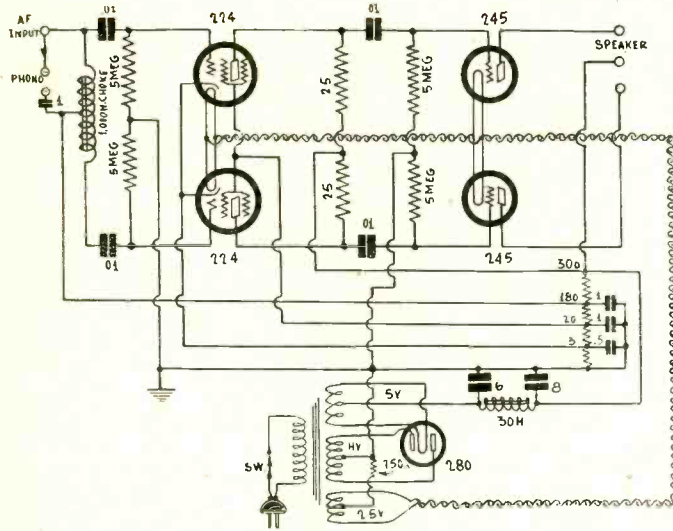

Fig. 1

This push-pull amplifier will work from a screen grid power detector and it is capable of a high undistorted output.

THE use of a center-tapped choke coil of high impedance after the detector makes it practical to couple a push-pull resistance coupled amplifier to a power detector of the screen grid type. While the circuit is not strictly push-pull, due to the use of this choke coil, the quality of the output is practically the same as if resistance coupling were used throughout because there is very little difference between the amplifying characteristics of a choke coupled and a resistance coupled circuit, provided that the impedance of the choke coil is so high that the gain is good on the lowest audio notes.

We have in Fig. 1 a two stage push-pull amplifier of this type, one utilizing two 224 screen grid tubes in the first stage and two 245 power tubes in the second. In view of the peculiar behavior of screen grid tubes in resistance-coupled circuits it might be argued that the amplification in this circuit is not great, especially the undistorted amplification, but the fact is that it is quite high enough.

## Treating the Screen Grid Stage

It must be stated, however, that the amplification in the screen grid stage will not be good unless the voltages on the elements are adjusted correctly, and the proper adjustment of them is quite different than if the same tube were used in a radio frequency amplifier with low resistance loads, or even in an audio amplifier with comparatively low resistance loads.

The important adjustment is the relation between the effective values of the plate and the screen voltages. Since the load resistance on a screen grid tube must be high if full advantage is to be taken of the high amplification factor of the tube, the effective plate voltage will be much lower than the applied because the voltage drop in the load resistance may be greater than the drop in the tube itself, and it is only the drop in the tube which determines the effective plate voltage. In fact, that is the effective plate voltage.

There are three ways of making the adjustment, and of course, these may be used in combination. The first is to make the applied plate voltage very high so that even after the larger part of it has been dropped in the load resistance the effective

voltage on the plate is still high enough. The second is to make the screen voltage comparatively low so that no matter what the drop in the plate load, the effective plate voltage remains higher than the screen voltage. The third is to put a fairly high resistance in series with the screen so that the effective screen voltage will decrease as the effective plate voltage decreases. This is effected by the fact that the plate and screen currents rise and fall together as the signal voltage rises and falls.

## Limiting Value of Plate Voltage

The applied plate voltage cannot be increased indefinitely for several reasons. First, there is only a limited voltage available in the B supply, and we cannot apply in the plate circuit a higher voltage than is supplied by the rectifier-filter. Second, we cannot increase the applied plate voltage beyond that point which makes the effective plate voltage about 180 volts, for the tube has not been designed to withstand a higher voltage. While a higher voltage may be applied it is not well to do so for the life of the tube is greatly reduced. Moreover, the plate current will be so high that the life of the coupling resistance may be greatly reduced. If the maximum voltage available is 300 volts it is safe to apply this provided we do so in series with a resistance of about 250,000 ohms.

While the applied voltage could be increased still further if the plate load-resistance were increased, little would be gained in the amplification by doing so, and it is not necessary to do it because the undistorted output of the screen grid tube will be greater than required to work the 245 power tube to its limit.

## Lowering Screen Voltage

Lowering the screen voltage is a good way of adjusting the circuit to prevent distortion in the amplifier. In the diagram the indicated applied plate voltage is 300 volts and the indicated screen voltage is 20 volts. For the 250,000 ohm plate load that is approximately the optimum combination, assuming that the effective grid bias on the screen grid tube is 3 volts negative. A somewhat higher amplification can be obtained by making the screen voltage a little higher, but if that is done the undistorted output is decreased.

The third method is to put a resistance in series with the screen lead. If this resistance be made 100,000 ohms the return should be made to a much higher voltage than when no resistance is used. In fact, it is safe to make it 67 or 75 volts. A low applied screen voltage in this case would not yield satisfactory results because the amplification would not be as high as it should be.

## Leak Resistances

The leak resistances in the push-pull amplifier illustrated are five megohms. This value is all right for the screen grid tubes, but in some instances they may be too high for the 245 tubes. A safer value would be one megohm. Higher values sometimes result in distortion, especially when the insulation of the grids from the plate voltage is poor. This happens in moist weather and when dust has settled on the set.

The center tapped choke may be the secondary of a good push-pull input transformer in case no specially designed choke is available. The secondary will work just as well because it has the required impedance and it is also balanced.

The B supply transformer is a Polo 245 and the choke in the filter is a Polo 245 choke, 30 henry, 100 milliamperes. The two by-pass condensers associated with the choke are electrolytics, but other condensers may be used provided the capacities are the same.

## Polo Choke Permits Long-Life Rectifier

The choke input to a filter system in a B supply consists of omission of the condenser next to the rectifier, making the choke connection only to the rectifier filament. A low inductance is used, 5 or 10 henries or so. The object is to avoid high starting drain on the rectifier, due to the condenser charging.

Polo Engineering Laboratories, 125 West 45th Street, New York City, manufactures a tapped choke, Cat. 245-CH, that permits choke input. The total choke DC resistance is 200 ohms. The first section is 40 ohms, the next 60 ohms, the next 100 ohms. It is suitable for 245 tube circuits. The choke may be used also as a center-tapped choke in push-pull coupled circuits, since one tap is at center, in which case only three leads would be used instead of four. The rating is 100 ma., the

inductance 30 henries.

Another Polo feature product is the power transformer, Cat. 245-PT. This has a 110 v. 50-60 cycle primary tapped at 85 volts for Amperite or Clarostat voltage regulator, or tap may be ignored if no regulator is used. The secondaries are 2½ volts, 16 amperes, 2½ volts, 3 amperes; 5 volts, 2 amperes, and high voltage, affording 300 volts D.C. @ 100 ma. All secondaries are center tapped.

A special filament transformer, 110 v. 50-60 cycle primary, provides two 2½-volt secondaries, one at 3 amperes. This is Cat. SP-FLT.

All three products are in polished aluminum cases, sturdy and highly attractive.



A Question and Answer Department conducted by Radio World's Technical Staff. Only Questions sent in by University Club Members are answered. Those not answered in these columns are answered by mail.

# Radio University

Annual subscriptions are accepted at \$6 for 52 numbers, with the privilege of obtaining answers to radio questions for the period of the subscription, but not if any other premium is obtained with the subscription.

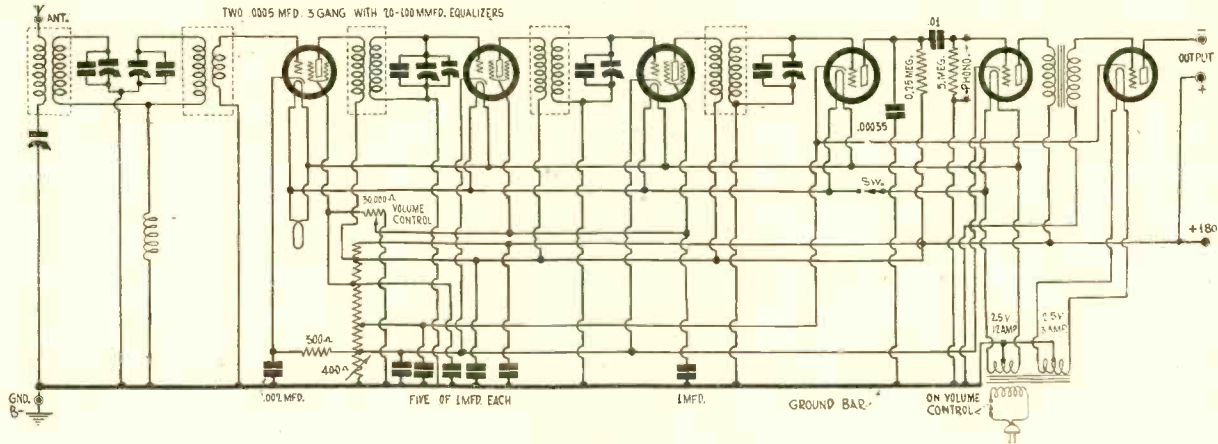

FIG. 873

THE CIRCUIT OF A VERY SENSITIVE RECEIVER INCORPORATING THREE SCREEN GRID TUBES AS RADIO FREQUENCY AMPLIFIERS AND A BAND PASS FILTER IN FRONT OF THE FIRST TUBE.

### Inductively Coupled Band Pass Circuit

WILL you kindly publish a circuit containing six or seven tubes using at least three screen grid tubes as radio frequency amplifiers? There should be at least one band pass filter in which the two tuned circuits involved are coupled inductively. Will you also indicate how they can be coupled by means of a condenser?—B. W. W.

Fig. 873 is a six tube receiver such as you request. The tuner ahead of the first tube is a band pass filter in which the two circuits are coupled by means of a small inductance of about 20 micro-henries. The two can also be coupled with a condenser by putting this in place of the coil. The capacity should be .04 mfd.

\* \* \*

### Trouble in Battery

WE have to run our battery charger at the same time that we use the set, or the stations are too weak. But when we use the charger, there is a strong hum which is objectionable.—C.N.

Presumably your storage battery is worn out, or else the connections are badly corroded. Test the battery with a voltmeter while it is being used, and also test with a hydrometer. You may find that one cell is very low. Sometimes you can have a new cell installed, but generally the best plan is to buy a new battery.

\* \* \*

### Microphonic Detector

I HAVE several detector tubes. The tube that gives the best results causes a bad ringing noise. You can hardly touch the set without starting the noise.—O. D.

It just happens that your most sensitive tube is microphonic. If your other tubes are new ones, you evidently did not obtain new and tested tubes of the proper grade, or the sensitivity would be O.K. The only thing to do is to try to have them exchanged, or else to buy a new and tested detector tube. Handle all tubes gently, as any jarring will loosen the elements in the glass supports and will make them microphonic. A microphonic tube in the detector socket is especially troublesome, since audio vibrations in the detector circuit receive the greatest amount of amplification.

\* \* \*

### Needs a Noise Filter

WE have an electric furnace-man in our house. It does not operate continuously, but when the motor runs the radio has humming interference. I have been advised to add a line noise filter to the set and also to attach a filter device to the furnace-man.—N. N. M.

By all means, get a suitable filter and attach it to the motor of the furnace apparatus. This is much more effective than any filter you could attach to the set. The manufacturers can undoubtedly tell you what type filter works best with their apparatus.

### Motor Generators for Farms

ARE the motor-generator devices recently described, for operating ordinary AC radios from a direct current line, built for 32-volt farm lighting units? My dealer tells me he thinks they are made for 110-volt direct current only.—J. J. D.

Ask him to put in an inquiry through his radio distributor. Manufacturers of these devices build them for 32 volts, 110 volts and for other special DC voltages in addition. The unit consists of a small DC motor, wound to suit the DC supply line available, and a generator of 110 volts alternating current, both in the same casing, affording a very convenient radio solution for the man with direct current in his home.

\* \* \*

### Grid Leak for 112A Detector

WHAT is the correct size for a grid leak for 112A? Fairly low resistance—about 1 megohm. Not utmost sensitivity, but best all-around performance should be the criterion.

\* \* \*

### Purpose of a Baffle Board

WHAT is the advantage of a baffle board for a cone speaker as large as 15 feet in diameter? Doesn't this size interfere with high notes?—L. Z.

No. But it does extend the low range lower.

\* \* \*

### Principle of Pick-up Unit

WILL you kindly explain how a phonograph pick-up unit works? That is, explain how a voltage is induced in the unit.—L.B.

If a coil is wound around a permanent magnet and a piece of iron is moved in the air gap of the magnet a voltage is induced in the coil as long as the iron moves. This is the basic fact of electro-magnetism. If the coil is around the moving iron a voltage is also induced. In most pick-up units the coil is wound around the moving iron, called the armature, and the needle is connected to the armature. As the needle moves along in the groove of the record the armature vibrates with respect to the magnet and a voltage is induced in the coil around the armature. This voltage has the same wave form as the groove in the record.

\* \* \*

### Line-Noise Filter

IF I connect a condenser across the 110-volt line would that take out some of the noise which now enters the receiver through the power pack? If any advantage can be gained in this way will you kindly give the value of the condenser to be used?—D. W.

If any noise or interfering signal does get into the set by this route a condenser of about 0.1 mfd. could be effective in cutting out the interference. A better way, though, is to use two of these condensers in series across the line, grounding the junction of the two. The condensers should be connected across the line on the transformer side of the line switch so that when the set is turned off the condensers do not remain across the line. These



condensers will draw some current and it is just as well to prevent this when the set is not in use.

**Measuring Sound Intensity**

**C**AN you suggest a method of measuring the intensity of a sound? I am interested in measuring the output of sound from loudspeakers and receivers.—B.W.F.

Measuring the absolute intensity of sound is not a simple proposition. There are various devices by means of which such measurements are made, but all require rather elaborate equipment and corrections of the observations. One device is the thermophone, which measures the change in resistance of a platinum wire due to changes in the temperature of the wire caused by the passing sound wave. Another device is the Rayleigh disc, which is a disc of very light material suspended on a light fibre. This disc turns by an amount proportional to the intensity of the sound wave that passes it provided it is placed in a certain angular position with respect to the direction of the sound wave. A small mirror attached to the suspending fibre reflects a beam of light and permits the measurement of the angle of rotation. Other devices are calibrated microphones. These must be calibrated against a thermophone or a Rayleigh disc.

**Line Ballast Selection**

**I**HAVE a Polo 245 power transformer which has a tap on the primary for use with a line ballast resistor such as the Amperite. There are several types of Amperite. Which one should I use with the transformer?—C.L.Y.

This question cannot be answered specifically because the size of Amperite to use depends on the current that will flow in the primary of the transformer, and that in turn depends on the number of tubes and type of tubes used in the circuit. Specify the circuit more accurately.

**How Tube Reverses Phase**

**I**F THERE is a simple explanation of how an amplifier tube changes the phase of the voltage, will you kindly give? While you are at it you might as well tell what phase is, for that may clear up the matter.—L.W.

What is meant in this connection is the difference of phase between the grid and the plate voltages, or the time difference between occurrences of the corresponding values. Both voltages go through sinusoidal variations at the same frequency. If the maximum of grid voltage in one direction occurs at the same time as the maximum of plate voltage in the opposite direction, the two are in opposite phase, or the phase difference is 180 degrees. If you take a curve between the grid voltage and the effective plate voltage, say in a resistance coupled amplifier, you will find that as you decrease the grid voltage (i.e., increase the bias) the plate voltage increases. When the grid voltage is least the plate voltage is greatest. Thus they are 180 degrees out of phase. To measure the effective plate voltage connect a voltmeter that draws no current between the plate and the cathode. Or connect a milliammeter in the plate circuit, find the drop in the coupling resistance in the plate circuit, and subtract the drop from the voltage of the plate battery.

**Bias Resistance Values**

**I**F three 224 screen grid tubes are put on the same grid bias resistor, what should the value be? Can the grid bias detector and the first audio frequency amplifier be put on the same bias resistor when both tubes are 227 type?—L.B.C.

One tube requires 300 ohms, two tubes require 150 ohms, and three 100 ohms. The grid bias detector and the first audio amplifier cannot be put on the same bias resistance because they do not require the same bias. While part of the bias resistor could be used for two tubes it is better to use entirely independent resistors.

**Balancing Push-pull Circuits**

**I**F the outputs of the two tubes in a push-pull amplifier are not equal on the high audio frequencies, is it possible to equalize them by connecting a condenser of suitable value across the winding across which the higher signal voltage appears? If so, what should the capacity of the condenser be to effect the balance?—T.R.

Balancing is done in this manner provided that the unbalance is due to capacity differences in the windings or across the windings externally to the transformer. Use a condenser the capacity of which is equal to the difference between the capacities across the two windings.

**Too High Voltage**

**H**AVE a B battery eliminator which gives much higher voltage than it should. For example, the voltage across the rectifier is 8 volts when it should be only 5 volts. All the other voltages are in proportion. What could the trouble be? I may mention that the rectifier tube blows out just as soon as I put it in the socket.—E.S.

There is undoubtedly some defect in the primary of the transformer. Possibly the transformer was designed to take a ballast for the purpose of steadying the voltage and you use it without this ballast.

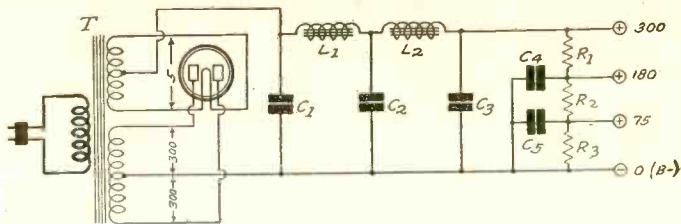

**FIG. 874**  
A B SUPPLY CIRCUIT OF THIS KIND WILL HANDLE A MODERN RECEIVER WITH SCREEN GRID TUBES AND 245s IN PUSH-PULL.

**A B Supply Circuit**

**P**LEASE publish a circuit diagram of a simple B supply incorporating one 280 type tube. Please specify the parts esary. Would a Polo 245 power transformer be suitable for the job?—T. C. F.

Fig. 874 is such a diagram. The power transformer may well be a Polo 245 and the two chokes may also be Polo, those rated at 30 henries and 100 milliamperes. The condensers may have the following values: C1, 2 mfd.; C2, 4 mfd.; C3, 8 mfd.; C4 and C5, 1 mfd. each. Larger values of condensers may be necessary for an average radio receiver utilizing one or two 245 power tubes. The resistance values in the voltage divider depends on the type of circuit and cannot be specified in the general case. If the bleeder current is 15 milliamperes and the currents to the 75 and 180 volt taps are 5 and 15 milliamperes, respectively, then the resistors may have the following values: R1, 3,400 ohms; R2, 5,250 ohms; R3, 5,000 ohms. The Polo 245 power transformer will have two 2.5 volt windings not indicated in the drawing of Fig. 874. One of these will deliver up to 16 amperes and may be used for all the heater tubes. The other will deliver up to 3 amperes, and may be used for either one or two 245 power tubes. All the windings on this transformer are center tapped.

**Set Not Selective, Yet Sharp**

**I**HAVE a receiver which is so sharp that a signal disappears if I move the dial one division. Still the set is not selective, for within that division there may be two or more stations which I hear at once. I can't understand why a selective set should not be able to separate the stations. Will you kindly explain?—W.H.J.

Your set is simply not selective enough. The apparent sharpness on the dial does not mean that it is selective. It simply means that the ratio of inductance to capacity in the tuned circuit is high.

**Best Volume Control**

**W**HAT is the best volume control to use in a screen grid battery-operated receiver? Would a variable resistance across the tuned circuit ahead of the detector be all right? How is a variable resistor across the antenna coil?—B.L.C.

A variable resistor across either the primary or the secondary of a tuned transformer is not good and should be avoided. A better way is to use a high resistance potentiometer, connecting the grid to the slider. If this potentiometer is across a tuned circuit it should have a resistance of 500,000 ohms. The potentiometer can also be used in the primary, especially in the antenna circuit. These can be used in either battery or AC sets. In the case of battery operated sets we have another volume control which is satisfactory, a rheostat in the negative leg of the filament of a radio frequency amplifier.

**Velocity of a Radio Wave**

**W**HAT is the significance of the constant 300,000 which is always used in converting meters to kilocycles and vice versa?—F.W.C.

This constant is the velocity with which radio waves travel in space and is expressed in kilometers per second.

**Intensity of Sound**

**I**N WHAT manner does the intensity of a sound vary with frequency, other things being the same?—H. B.

The energy in a sound wave is proportional to the square of the frequency. Also, the energy in the sound wave is proportional to the square of the amplitude. That is, the energy is proportional to the square of the product of the frequency and the amplitude. Suppose the intensity of a 10,000 cycle sound is the same as that of a 100 cycle note, that is, the two have equal energy. What is the ratio of the amplitudes? The relation given above tells us that the squares of the products of frequency and amplitudes are the same. Therefore the products themselves are equal. That is, if the amplitude of the 10,000 cycle sound is  $a$  and the amplitude of the 100 cycle note is  $A$ , then  $10,000a = 100A$ . Therefore the amplitude of the low tone is 100 times greater than that of the high frequency sound.



# SEVEN STATION APPEALS AWAIT COURT DECISION

Washington.

There are seven appeals pending in the District Court of Appeals of the District of Columbia that involve questions of interference, censorship of programs, the right of the Federal Radio Commission to insert conditions into the renewal licenses without prior hearing, and the definition of "public interest, convenience and necessity."

Of the seven appeals two of local interest to listeners in the New York area concern WGBS and WMCA. The question here is whether these two stations within the metropolitan limits do operate without noticeable interference. They are separated 30 kilocycles on the broadcast spectrum, which is considered to be ample by some technical authorities.

## Hospital Station Replies

In Milford, Kansas, George E. Strong, attorney for KGKB, is arguing to have the recent decision of the Commission denying the renewal of the existing license set aside. The Commission claims that the station conducted by a radio "medical question box" is against the law. The station denies this. KFKB is owned and operated by the Brinkley Hospital and Pharmaceutical Association.

Marquette University, of Milwaukee, Wis., also was denied its petition for an increase of power, and assignment to the 900 kilocycle channel. The Commission in denying the petition said that the change was not warranted as the station would not operate continuously. This station is at present sharing time with WISN on the 1,120 kc channel.

## Interference Feared

Transfer to the 900 kc channel would result in interference with WBBL, owned and operated by the Department of Agriculture of Wisconsin, which may consolidate with WHA, of the University of Wisconsin, and the two merged stations would then operate on the 940 kc channel. The granting of the petition, the Commission also claims, would result in interference with WBEN, at Buffalo, 460 miles distant; WKY, of Oklahoma City, 730 miles away, and WLBL, at Stevens Point, 140 miles from Milwaukee.

## DeForest Asks Review Of Langmuir Decision

Washington.

The De Forest Radio Company, through its attorneys, has filed a petition for a writ of certiorari with the United States Supreme Court to have its case against the General Electric Company reviewed. The suit concerns the validity of the Langmuir high vacuum patent, over which there has been much litigation during recent years.

The radio industry believes that if the Langmuir claims are upheld by the Supreme Court, a virtual monopoly will exist in the tube-making industry. Samuel E. Darby, one of the attorneys for the De Forest Company, stated that if the Supreme Court reviews the case it was his opinion that the patent would be adjudged invalid. Four judges have at various times been of the opinion that the patent is invalid, and another has reversed his opinion. The United States Circuit Court at Philadelphia recently upheld the Langmuir contentions.

# Forum

## Value of a Tone Control

RADIO WORLD has stated that many purchasers of radio receivers are satisfied to let the engineers who design the receivers establish what they consider the best tone quality and fix it at that point. In general this is sound practice, although there are cases in which a variable tone control is desirable to obtain natural reproduction. I realize that this statement is contrary to general opinion to the effect that tone control produces an unnatural although perhaps a pleasing quality.

But there are some broadcast stations whose transmission is not perfect and in which the higher registers are greatly exaggerated. This is true of one of our locals, WIOD, and in such cases a tone control is absolutely necessary to reduce the exaggerated high frequencies to their normal value. Some orchestras, like Lucky Strike for example, use a preponderance of high-pitched instruments, which are difficult for even the best of broadcast stations to transmit satisfactorily, and when such a combination comes over a station that stresses the high frequencies the result is bad.

If one has a good receiver possessing high fidelity, it is an interesting experiment when a well-distributed chain program is on to tune from one chain station to another and note the difference in quality from the various transmitters. When this is done it will be found that only a very few are what might be called good.

A. B. GARDNER  
Box 296, Coconut Grove, Fla.

## Radio Pillow Devised for Hospitals and Trains

A "singing" and "talking" radio pillow for use in hospitals and Pullman cars has been developed by the Engineering Products Division of the RCA Victor Company, Inc.

The radio pillow is of regulation hospital size, and is made of specially selected sponge rubber in which a sensitive radio reproducing unit is concealed. The pillow is so constructed that the sound that permeates it cannot be heard except by resting the head on the pillow. The radio pillow was designed especially for use in hospitals to replace ordinary earphones, and also the loudspeaker, which may be disturbing to other patients.

The new pillow, according to its sponsors, may be sterilized like an ordinary pillow, and the pillow-cases changed at will. The patient lies in a natural reclining or sitting-up position to hear the radio programs. A connecting cord of ample length is plugged into the centralized radio receiving system.

## A THOUGHT FOR THE WEEK

*FLOYD GIBBONS certainly started something when he began his series of lightning-like, straight-from-the-shoulder staccato addresses over the air. His was a new and refreshing, if somewhat breathless, method that caught the fancy of the public. Other broadcasters are following in his footsteps. We have in mind one man in particular who, six months ago, was deliberate in utterance, didactic and prosy in method, and altogether dry and uninteresting. Today he speaks as if he were working on all cylinders and seems bound to contract high blood pressure. Score another for Floyd Gibbons.*

## Succor Approved for Station Hemmed In

Washington.

Chief Examiner Ellis A. Yost, of the Federal Radio Commission, has recommended that WHIS, at Bluefield, West Va., be granted an increase of power, and also be shifted to a regional channel of 1,410 kc. The station's present assignment is 100 watts on the local channel of 1,420 kc. One-half time is also requested on the regional channel.

The supporting testimony submitted to the Commission reveals that the station is located in a mountainous country and in the middle of a great mining district. The surrounding country is covered by a network of telegraph, and power lines with the result that the losses by absorption are excessive, the station being barely able to cover the City of Bluefield.

## Britain Protests Soviet Broadcasts

London.

The British Government has registered a protest to the Soviet Government due to the nature of the propaganda that reaches the confines of the British Isles.

The propaganda emanating from Russia is intended for the ears of the working man but scarcely ever does it reach this objective because the working man in England cannot afford the type of receiver that is sensitive enough to reach over that distance. The type of set sensitive enough to bring in Russian stations has at least five tubes and costs up to \$175.

In another instance the German Government protested to the Soviet Government because of the revolutionary indictments that emanated from the Moscow stations in the German language.

## WWJ Seeks 50 KW and Clear Channel

Washington.

The Federal Radio Commission has been petitioned by the Evening News Association of Detroit, which operates WWJ on 920 kc., for permission to use the maximum power of 50,000 watts. The station is operating under its old frequency assignment which provides for the use of 1,000 watts. In addition to the above it requests transfer to the cleared channel of 1,020 kc. This frequency is now assigned to KYW, which is in the fourth zone, and the assignment having been made from the second zone by previous arrangement. Three appeals relative to this borrowing of zone frequency are pending at present in the Court of Appeals of the District of Columbia.

## KFYD Charges Error, Asks for a Rehearing

Washington.

W. O. Ansley, representing KFYD, of Abilene, Tex., has filed a petition for a rehearing with the Federal Radio Commission on the question of the use of 1,000 watts on 550 kc. and also use of unlimited time. These requests had been denied by the Commission.

It is alleged that reconsideration of the case will demonstrate that a court unintentionally based its opinion on statements in the Commission's brief that are not wholly accurate. KFYD is now listed under 1,420 kc, with 250 watts day and 100 watts after 6 p.m., on part time.



# FIVE STATIONS RECOMMENDED TO BE OUSTED

The Federal Radio Commission, represented by Examiner Elmer W. Pratt, has recommended the removal from the air of five stations for infractions of the law. The alleged offences include excessive frequency deviations, failure to announce the fact that certain musical selections were phonograph records, and failure to announce the station call letters at an interval of approximately fifteen minutes.

There are, however, two stations that are recommended for reinstatement—WMBQ, of Brooklyn, N. Y., and KTRH, of Houston Tex. The Brooklyn station was adjudged not liable due to the fact that the frequency controlling crystal developed a fault unknown to the monitor, and the station suspended operation directly the deviation from the normal assigned frequency was ascertained.

## Ownership Changed

The Houston station was cited for frequency deviation also, but in the time that elapsed between the suspension notice the station changed owners and subsequently the equipment was improved and further trespassing in this regard will not occur again, it was promised. The new owner is the KTRH Broadcasting Company.

The recommended stations to be suspended are WLTH, of Brooklyn, N. Y.; WCLS, of Joilet, Ill.; WWRL, of Woodside, L. I.; WKBC, of Jersey City, N. J., and WKBQ, of New York City.

The examiner reserves the right to recognize the mitigating circumstances in each case.

## Cites Repeated Offence

WKBC is held by the examiner to be guilty of excessive frequency deviation and failure to announce phonograph records as such. The phonograph violation is said to have been committed for a period of at least seven days continuously.

WCLS is adjudged guilty of operating the station with an unlicensed operator, and this violation is construed to be a deliberate attempt to evade the law.

## 80 Women Participate In Television Stunt

Eighty members of the Engineering Women's Club were among the guests who witnessed a series of television experiments in New York City. The function was termed a television tea and was held in a suite adjacent to the offices of the American Telephone & Telegraph Co., at 195 Broadway, and also at the Bell Telephone Laboratories, at 463 West street.

The members of the two groups were in telephone-television communication with one another, they being called one by one to the booth where they exchanged greetings. The function was declared a success.

## RMA MOVES FOR LOWER RATES ON TUBES

Preliminary to an application, if possible, for lower freight rates on radio tubes, the Radio Manufacturers Association traffic department has begun a survey to determine if the present ratings on tubes are reasonable from a traffic standpoint.

## Literature Wanted

Readers desiring radio literature from manufacturers and jobbers concerning standard parts and accessories, new products and new circuits, should send a request for publication of their name and address. Send request to Literature Editor, RADIO WORLD, 145 West 45th Street, New York, N. Y.

Russell A. Park, 89 W. Willis, Detroit, Mich.  
G. K. Snyder, 623 N. Maryland Ave., Glendale, Calif.  
C. J. Allen, 203 Woodside Road, Royal Oak, Mich.  
Thomas. F. Taylor, 46th School Sqdn. A. C., Brooks Field, San Antonio, Tex.  
G. L. Chandler, Stuarts Draft, Va.  
R. D. Scott, 2327 Casper Ave., Detroit, Mich.  
Geom. Mario Foco, Corso C. Alberto, N. 5. Vercelli, Italy.  
H. G. Blackshear, Plains, Ga.  
Wm. S. Cramer, 6013 Summer St., West Philadelphia, Pa.  
George Bennett, 353 Massasoit Ave., East Providence, R. I.  
J. Bruns, 307 N. Michigan Ave., Battle Creek, Mich.  
Leslie P. Whitten, 207 Somerset Ave., Plainfield, N. J.  
Jack Roberts, 861 Bond St., Elyria, Ohio.  
H. W. Blake, c/o Auto Radio Corp. of Calif., 1301 N. Western, Hollywood, Calif.  
A. B. Welch, 628 Atlantic Ave., Corpus Christi, Texas.  
J. Ullrich, 45 Williams, Malden, Mass.  
Clarence N. Heffelfinger, R.F.D. No. 1, Temple, Pa.  
Walter F. Forbes, Box 524, Buhl, Idaho.  
John N. Boyer, Laureldale, Pa.  
Geo. W. Bank, 223 S. 53 St., Philadelphia, Pa.  
C. Kenneth Moore, R.D. No. 1, Waynesburg, Pa.  
J. J. Kearns, 19 Bonvue St., N.S., Pittsburgh, Pa.  
Z. T. Sharkey, Box 260, Charleroi, Pa.  
Gustav Boettcher, 230 Bartlett St., Manchester, N. H.  
William Fales, West End Thread Co., Millbury, Mass.  
R. H. Worrall, 1621 Riggs Pl., N. W., Washington, D. C.  
H. L. Bumbaugh, 215 S. New Hampshire Ave., Los Angeles, Calif.  
Wm. L. Brennan, 33 Bayfield St., Barrie, Ont., Canada.  
Bert Halvorson, Box 218, Sault Ste. Marie, Mich.  
E. O. Myers, 2027 Scott St., Covington, Ky.  
E. M. Harhour, Handley, W. Va.  
Max Schwarz, Apt. 16, 31-77 32nd St., Astoria, L. I.

## NEW CORPORATIONS

Radio Transportations, talking pictures—Atty. Miller & Miller, 25 West 44th St., New York, N. Y.  
American Radiostat Corp., Wilmington, Del., patents—Corporation Trust Co.  
Mackay Sound-on-Film, Inc., New York, N. Y.—Delaware Incorporating Co.  
Presto Corporation of America, Wilmington, Del., agents for radio, voice reproduction attachments—American Guaranty and Trust Co.  
Harvard Tube Testing Stations, Inc., Dover, Del., radio and television apparatus—United States Corporation Co.  
Radio Quality Group Service, amusements—Atty. Wise & Seligsberg, 150 William St., New York, N. Y.  
Beach Radio Service—Atty. D. Weil, Rockaway Park, Queens, New York, N. Y.  
WBEN, radio broadcasting—Atty. Wilcox & Van Allen, Buffalo, N. Y.  
Automatic Phonograph Corp., New York, N. Y., Sound-recording devices—Prentice Hall, Inc., of Delaware.  
Atlantic and Pacific Television Co., sight, sound reproductions—Atty. J. A. Shay, 25 West 43rd St., New York, N. Y.  
Tri-State Broadcasting Corp., Wilmington, Del., broadcasting—Delaware Registration Trust Co.  
L. Dubrow & Sons, Inc., Philadelphia, Pa., radio, musical instruments—Corporation Guaranty and Trust Co.

## President of Austria Heard on Short Waves

Austria was linked with the United States recently via an international network when an address by Dr. Wilhelm Miklas, president of Austria, was transmitted throughout Europe, and to the United States via short waves from London, England. The speech was handled on this side by the Columbia Broadcasting System.

Dr. Miklas spoke from the executive chamber of the Ballhaus Palace, at Vienna. This room was used by statesmen who met to remake the map of Europe, following Napoleon's defeat at Waterloo.

## Electrad Has Line of Three Power Amplifiers

Electrad, Inc., 175 Varick Street, New York City, announces the addition of two newly perfected power amplifiers utilizing the Loftin-White direct-coupled system, which with model A-245, completes a line of amplifiers suitable for the present-day requirements of sound amplification.

The C-250 amplifier provides 10.35 watts of undistorted output with but .3 volts input, and a power consumption of only 160 watts. The C-250 embodies all modern features, with tone control and hum compensator. Completely assembled on metal sub-panel. Utilizes one 224, two 250 and two 281 tubes.

The A-250 amplifier provides 4.6 watts of undistorted output with but .28 volts input and a power consumption of 85 watts. Built on rugged metal sub-panel. Requires one 224, one 250 and one 281 tube.

The Electrad A-245 amplifier is the "father" of the direct-coupled family, being the first practical unit. It provides 1.6 watts undistorted output with .25 input. Power consumption only 40 watts. Requires one 224, one 245 and one 280 tube. Prepared in kit form or completely assembled ready for operation.

## Air Beacons Tested by Aerials in Autos

The Aeronautics Branch of the Department of Commerce is kept busy checking up on the tests made to assure that the directional radio beacons at the airports of the nation are functioning properly. At present it has only one test plane equipped with apparatus for this purpose, and the demands have been taxed to the extent that it has been found necessary for economic reasons to use a number of automobiles with checking equipment.

The machines are provided with a portable antenna which can be erected to a sufficient height and orientated to the desired position.

The test equipment is not identical with that used on the airplane, but experimental check previously made showed that a good degree of accuracy was obtained. There are at present 35 airport beacons in operation, and in addition there are 20 under construction. Those recently placed in operation follow: Auburn, Calif.; Columbus, O.; Fresno, Calif.; Fort Madison, Ia.; Indianapolis, Ind.; Moran, Kans.; Saugus, Calif., and Ferre Haute, Ind.

## New Polish Station About to Take Air

Warsaw, Poland. The American Legation has transmitted to the Department of Commerce information regarding the broadcasting station now under construction at Raszyn, on the outskirts of Warsaw. The operator is the Polish Radio Company, and the apparatus for the transmitter is being obtained from the Marconi Wireless Telegraph Co., of England.

The station when completed will cost 5,000,000 zlotys (about \$561,000). The station is expected to be operating this month. Its wavelengths will be 200 meters. The station uses the latest type of equipment and is said by engineers of the Marconi Company to represent the most modern trend in European broadcasting station design.



# The New Jiffy Tester

## Chromium-Plated Case and Accurate Meters

**A** NEW and improved Jiffy Tester, improved in both performance and appearance, is Model JT-N. The meters are of the moving iron type. Tested on precise batteries, they show errors not exceeding 2%. As for appearance, the case is first copper plated, then nickel plated, then chromium plated, giving a lustrous, permanent, non-peeling non-rusting finish. It is the same finish found on hardware in fine automobiles. The handle and lock strap are genuine leather.

Jiffy Tester, Model JT-N, consists of three double-reading meters, with cable plug, 4-prong adapter, test cords and screen grid cable, enabling simultaneous reading of plate voltage, plate current and filament or heater voltage (DC or AC), when plugged into the socket of any set. The ranges are filament, heater or other AC or DC: 0-10 v, 0-140 v; plate current: 0-20, 0-100 ma; plate voltage: 0-60, 0-300 v. It makes all tests former models made. Each meter is also independently accessible for each range. The entire device is built in a chromium-plated case with chromium-plated slip-cover. Instruction sheet will be found inside. Order Cat. JT-N.

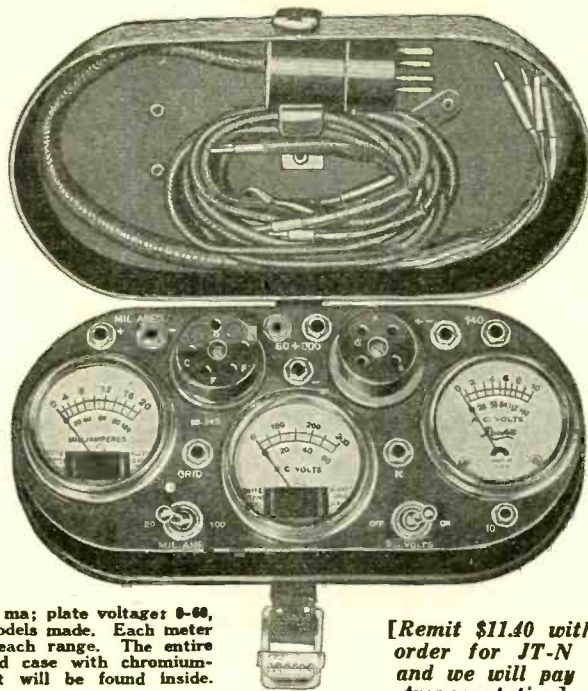

[Remit \$11.40 with order for JT-N and we will pay transportation]

**GUARANTY RADIO GOODS CO.**  
143 WEST 45th STREET (Just East of Broadway) NEW YORK, N. Y.

## Short-Wave Converter Series

In the November 8th issue of RADIO WORLD there began a remarkable series of articles dealing with the construction of short-wave converters that really do work, and that work well. Besides, the cost of parts is low. One model, 30 to 110 meters, no plug-in coils, may be built of parts costing less than \$5, for battery operation, or for AC with extra filament transformer external, while another model, 10-200 meters, two plug-in coils, using somewhat superior parts, filament transformer built-in, can be made up by you for less than \$10. Surely these are prices within the reach of all.

Low price and high achievement go hand in hand in these designs by Herman Bernard.

The series ran in the November 8th, 15th, 22nd and 29th, and December 6th, 13th, and 20th issues. Send \$1 and we will forward these seven issues and a blueprint of the AC \$5 model.

RADIO WORLD, 145 West 45th Street, New York, N. Y.

Enclosed please find \$1.00 for which send me the November 8th, 15th, 22nd and 29th, and Dec. 6th, 13th and 20th issues, containing the series of articles on short-wave converters of extremely low price, and a blueprint of the AC \$5 model.

Name .....

Address .....

City ..... State .....

### DIAMOND PAIR, \$1.20



GUARANTY RADIO GOODS CO.  
143 W. 45th St. New York, N. Y.

**TEMPLE DYNAMIC SPEAKER—**  
Finely carved wood grilled front.  
\$15.34. Guaranty Radio Goods Co.,  
143 W. 45th St., N. Y. C.

## SCREEN GRID COILS

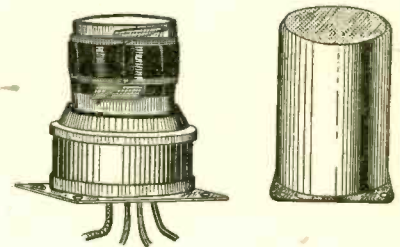

**H**IGH-GAIN shielded radio frequency transformers for screen grid circuits using 222, 224 or 232 tubes for RF, and any kind of detector. The primary has a high impedance—45 turns—and is closely coupled to the secondary over which it is wound, with an insulating wrapper in between, 42/10,000 inch thick. The diameter of the bakelite tubing is 1 3/4 inches.

Each coil form is solidly set in a veneer base, to support and elevate the coil, and equalize the distance from the shield walls. The base is secured to an aluminum template over which the drawn aluminum shield fits snugly, so that the coil is utterly rigid inside at all times. The coils are packed in matched sets of fours, tested for identical inductance on a bridge circuit. Thus they are of precision type, necessary for full effectiveness from gang tuning.

Primary leads: shield wire, beginning; red, end. Secondary leads: blue, beginning; yellow, end. Shield size is 2 1/8" x 2 1/8" x 3/4".

The same type coil is used as antenna input and as interstage coupler and will feed into any type of detector, screen grid or otherwise.

For .00035 mfd. tuning order Cat. 40-80 @ \$1.50  
Matched set of four for .00035 mfd.  
Cat. 40-80-MF ..... 6.00

[The matched four for .00035 mfd. may be used for intermediate frequency amplification at frequencies below 550 kc, by putting a .00035 mfd. fixed condenser across the secondary and a 100 mmfd. equalizer across the same circuit. We can supply the .00035 mfd. fixed condensers @ 15c each and the 100 mfd. Hammarlund equalizers @ 35c each.]

For .0005 mfd. tuning order Cat. 40-70 @ \$1.50  
Matched set of four for .0005 mfd.  
Cat. 40-70-MF ..... 6.00

Remit with order for coils and we pay transportation. C.O.D. orders filled.

### SCREEN GRID COIL COMPANY

143 West 45th Street  
New York, N. Y.

[Just East of Broadway]

## Two for the price of One

Get a FREE one-year subscription for any ONE of these magazines:

- CITIZENS RADIO CALL BOOK AND SCIENTIFIC DIGEST (quarterly, four issues).
- RADIO (monthly, 12 issues; exclusively trade magazine).
- RADIO ENGINEERING (monthly, 12 issues; technical and trade magazine).
- RADIO INDEX ((monthly, 12 issues) Stations, programs, etc.
- SCIENCE & INVENTION (monthly, 12 issues; scientific magazine, with some radio technical articles).
- AMERICAN BOY—YOUTH'S COMPANION (monthly, 12 issues; popular magazine).
- BOYS' LIFE (monthly, 12 issues; popular magazine).

Select any one of these magazines and get it FREE for an entire year by sending in a year's subscription for RADIO WORLD at the regular price, \$6.00. Cash in now on this opportunity to get RADIO WORLD WEEKLY, 52 weeks, at the standard price for such subscription, plus a full year's subscription for any ONE of the other enumerated magazines FREE! Put a cross in the square next to the magazine of your choice, in the above list, fill out the coupon below, and mail \$6 check, money order or stamps to RADIO WORLD, 145 West 45th Street, New York, N. Y. (Just East of Broadway).

Your Name .....

Your Street Address .....

City ..... State .....

- If renewing an existing or expiring subscription for RADIO WORLD, please put a cross in square at beginning of this sentence.
- If renewing an existing or expiring subscription for other magazine, please put a cross in square at the beginning of this sentence.

RADIO WORLD, 145 West 45th Street, New York, N. Y. (Just East of Broadway)

**DOUBLE VALUE!**



# SHORT-WAVE SPECIALTIES

## EXTRA-SPECIAL FREE OFFERS OF SUBSCRIPTION PREMIUMS!

RADIO WORLD, now in its ninth year, is the first and only national radio weekly, and publishes the latest, up-to-the-second news of circuits, both of kit types and of 1931 commercial receivers, as well as news of happenings in the broadcasting field. Lists of broadcast and short-wave stations are published regularly. You get your information weekly—which means quickly—and you get it accurately, so be sure to become or remain a subscriber for RADIO WORLD. We are able to offer now specially attractive premiums, and ask you to make your choice from the well-chosen variety of parts offered on this page and on the opposite page. When ordering, please use coupon.

The regular subscription rates are: \$6 for one year, 52 issues, one each week; \$3 for 6 months, (26 weeks); \$1.50 for three months, (13 weeks); \$1 for 8 weeks; 15c per single copy.

### TUBE-BASE TYPE COILS

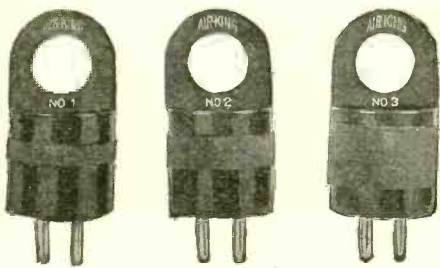

Three finger-handle type plug-in coils, wound on tube-base diameter, although of greater height than a tube base, for short wave plug-in service, where a 4-prong (UX) tube socket is used as coil receptacle. There are two separate windings, tightly coupled. The coil socket connections are: plate prong to plate, filament plus to phones; grid prong to grid and ant.; filament minus to stator of a feedback condenser. The tuning condenser (stator to grid prong, rotor to filament plus prong) may be .0015 or more for 15 to 110 meters; the feedback condenser .0025 mfd. B voltage is supplied through phones or audio transformer primary. Order PR-TBC free (less coil socket) with 6 mos. (26 weeks) subscription @ \$3.00

### PRECISION PLUG-IN COILS

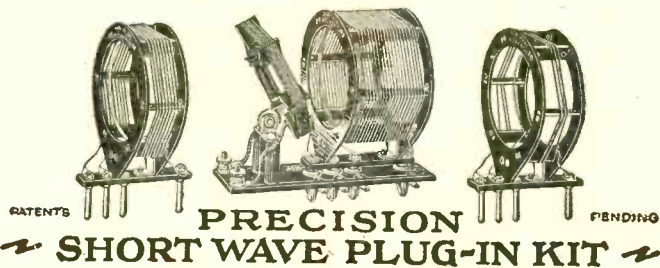

The finest short-wave coils, of de luxe construction, wound on ribs, affording 97% air dielectric, and available for various capacities of condensers, as listed below. All precision short-wave coils are provided with receptacle bases and apply to standard circuits.

For .001 or .0015 mfd. tuning; three plug-in coils with receptacle base as illustrated, with adjustable primary built onto receptacle, 15 to 150 meters. Order PR-AK-1, free with one year's subscription @ \$6.00.

For .0025 or .002 mfd. tuning; only two coils are required, for 15 to 150 meters. Order PR-AK-2, and get two coils, receptacle and adjustable coil (third inductance) built in. Free with nine months' subscription (39 weeks), at regular rate, \$4.50.

Note—We can supply .0015 mfd. (PR-H-15) or .002 mfd. (PR-H-20) Hammarlund short-wave midline condenser, swings inside 2-inch diameter, with three months (13 weeks) additional subscription @ regular \$3 rate.

### "DIAMOND" PAIR IN STANDARD AND DE LUXE TYPES



The Diamond of the Air is a popular circuit using an antenna coil and a three-circuit tuner. For this circuit the standard Diamond pair of coils consists of two, wound on 3" diameters, except for rotor on smaller form. The standard pair may be obtained for .0005 or .00035 mfd. tuning. Ticker coil has single hole panel mount. For .0005 mfd. order PR-SDP-5, with blueprint, free with a six-month subscription (26 weeks) @ \$3.00. For .00035 mfd. order PR-SDP-35, free with 6-month subscription @ \$3.00.

These coils will give extreme satisfaction and are excellent for the Diamond of the Air, being specified by Herman Bernard, the designer of the circuit.



De luxe Diamond pair, with large primaries center-tapped. For the Diamond use center tap and one extreme of the primary for antenna circuit, RF coil (at right); use full primary on tickler (lowest winding at left). The de luxe pair have silver-plated wire, for loss-reduction, wound on moulded bakelite, with threadings, so coils are space-wound to reduce distributed capacity. Three-circuit coil is single-hole panel mount. Additional holes for optional base mounting on both, using brackets (not supplied.) For .0005 mfd. only. (None for .00035 mfd.) Order PR-GWN free with a year's subscription (52 issues) @ \$6.00.

### GET THE COMPLETE DATA ON SHORT-WAVE CONVERTERS

Short-wave converters are all the rage. They enable you to tune in short waves on a broadcast receiver of any kind. A serial article by Herman Bernard, on this topic, discussing several models, with full-size picture diagrams, was published in the November 8th, 15th, 22nd, 29th, December 6th, 13th and 20th issues. Send \$2 for 17 weeks' subscription and get these seven issues free. Order PR-SWCS.

### PARTS FOR A SHORT-WAVE CONVERTER

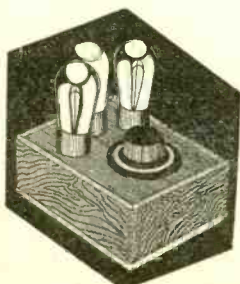

No matter what type of broadcast receiver you have, you can get short waves by using a short-wave converter built of parts we can supply. The panel is only 5 x 6 1/2 inches. There is only one tuning control. No squeals, howls or body capacity. Two models are available, one for A.C., the other for battery operation. The battery model uses three 227 tubes with heaters in series. Full details supplied with order.

All parts for A.C. model (less filament transformer, less three 227 tubes), order PR-SUP-3A, free with a year's subscription @ \$6.

All parts for the battery model (less three 227 tubes), free with a year's subscription for Radio World @ \$6.00. Order PR-SUP-3B.

A third model (of different appearance than illustrated) enables filament transformer to be built in. All parts, including filament transformer; two wound plug-in coils, 15-200 meters. Hammarlund condenser, (less tubes), order PR-SUP-3FS free with two-year subscription @ \$12.

### PLEASE USE THIS COUPON!

RADIO WORLD,  
145 West 45th Street, New York, N. Y.

I hereby take advantage of your extra-special premium offers and subscribe for RADIO WORLD for the number of weeks specified in the list below. Please send indicated premium. My remittance of \$ ..... is enclosed. RW-1-10

- |  |  |
|--|--|
| <input type="checkbox"/> PR-TBC (26 wks.) \$3.00 | <input type="checkbox"/> PR-SDP-35 (26 wks.) \$3.00  |
| <input type="checkbox"/> PR-AK-1 (52 wks.) 6.00  | <input type="checkbox"/> PR-GWN (52 wks.) 6.00       |
| <input type="checkbox"/> PR-AK-2 (39 wks.) 4.50  | <input type="checkbox"/> PR-SWCS (17 wks.) 2.00      |
| <input type="checkbox"/> PR-H-15 (13 wks.) 1.50  | <input type="checkbox"/> PR-SUP-3A (52 wks.) 6.00    |
| <input type="checkbox"/> PR-H-20 (13 wks.) 1.50  | <input type="checkbox"/> PR-SUP-3B (52 wks.) 6.00    |
| <input type="checkbox"/> PR-SDP-5 (26 wks.) 3.00 | <input type="checkbox"/> PR-SUP-3FS (104 wks.) 12.00 |

Name .....

Address .....

City ..... State .....

Please put cross here if renewing an existing subscription.



# Why Not "Money Back" on Tubes?

## Any Lesser Guarantee Inadequate in Present Market



Standard 201A with UX base.

THE economic depression and resultant predicament of some tube manufacturers have resulted in the dumping on the market of tubes of inferior calibre, tubes that failed in the factory test for "firsts," and were sold to distress merchandise operators "as is" at a few cents apiece. These tubes often are in private brand cartons, but do not bear the name of the real manufacturer.

Rextron tubes are made by Rextron.

The estimate a manufacturer places on his tubes in the present chaotic tube market is well measured by the guarantee that backs up the tube. Replacement guarantees are encouraging but not conclusive. Nothing less than "money-back" will do now. Rextron tubes are sold on a 10-DAY MONEY-BACK GUARANTEE. Use them ten days. If not fully satisfied, return the tubes and your money will be refunded at once.



Each tube is packed in an especially rugged and secure carton as precaution against damage in transit. We—NOT YOU—run the damage risk.

### Red-Hot Speed in Shipments!

#### GENERAL AND SPECIAL PURPOSE TUBES

(Cat. RX-1)—201A, detector, amplifier, 1/4 amp. filament	1.00
(Cat. RX-2)—226, amplifier for 1 1/2-v. AC on filament	1.00
(Cat. RX-3)—227, detector, amplifier; 2 1/2-v. AC on heater	1.00
(Cat. RX-4)—171A, power tube, 1/4 amp. filament; battery operation	1.00
(Cat. RX-5)—171, power tube, 1/2 amp. filament; AC	1.00
(Cat. RX-6)—240, high mu tube; battery operation	1.00
(Cat. RX-7)—120, power tube for dry cell operation	1.00
(Cat. RX-8)—UX189, detector, amplifier; long prongs	4.00
(Cat. RX-9)—UV189, detector, amplifier; short prongs	1.00
(Cat. RX-10)—112, power tube, 1/2 amp. fil.; AC operation	1.00
(Cat. RX-11)—112A, power tube, 1/4 amp. fil.; battery operation	1.00
(Cat. RX-12)—200A, special detector; highly sensitive	1.00
(Cat. RX-13)—224, screen grid AC tube; 2 1/2-v. AC on heater	1.00
(Cat. RX-14)—245, power tube for AC operation	1.00
(Cat. RX-15)—201A special RF amplifier	1.00
(Cat. RX-16)—201A special detector	1.00
(Cat. RX-17)—201A special audio amplifier for transformer	1.00
(Cat. RX-18)—201A special AF amplifier for resistance or impedance	1.00
(Cat. RX-19)—201A switch type; if one filament burns out switch on the other	1.00
(Cat. RX-20)—112 switch type	1.00
(Cat. RX-21)—171 switch type	1.00
(Cat. RX-22)—226 adapter; for converting battery sets to AC	1.00
(Cat. RX-23)—227 adapter; for converting battery sets to AC	1.00
(Cat. RX-24)—171A adapter; for converting battery sets to AC	1.00
(Cat. RX-25)—WD12, detector, amplifier; dry cell operation	2.95
(Cat. RX-26)—250, power tube; for AC operation	2.00
(Cat. RX-27)—201A, shield tube, completely bakelite encased	2.10
(Cat. RX-28)—222, screen grid tube, for battery operation	3.85
(Cat. RX-29)—Tellon television neon gas tube	4.50
(Cat. RX-30)—Photo-electric cell, 2 inches	2.95
(Cat. RX-31)—210, power tube; for AC operation	2.00

#### RECTIFIER AND CHARGER BULBS

(Cat. RX-32)—125 milliamperes gaseous rectifier; BH type	2.85
(Cat. RX-33)—2 ampere charger bulb, old style; top connector	2.85
(Cat. RX-34)—2 ampere charger bulb; new style, base connector	4.95
(Cat. RX-35)—5 ampere charger bulb; top connector	4.95
(Cat. RX-36)—8 ampere charger bulb; top connector	1.00
(Cat. RX-37)—280 full wave rectifier	2.95
(Cat. RX-38)—281 half wave high wattage rectifier	1.00
(Cat. RX-39)—Rectifier for Freshman Master B Eliminator	1.00



227 detector and RF audio amplifier.



The AC adapter tubes permit changing a battery set to AC operation, as binding posts permit extra connections. For 226, 227 or 171A.



The 2-ampere charger, new type.



The 2-ampere charger, with a connector at top.



High capacity charger, for 5 and 6 amperes.



High-mu tube for battery operation, equivalent to the 240, but listed as 201A high mu.

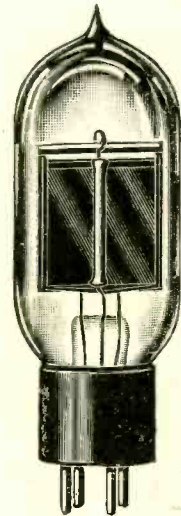

One of the most popular tubes for television is the Tellon, a neon gas tube.

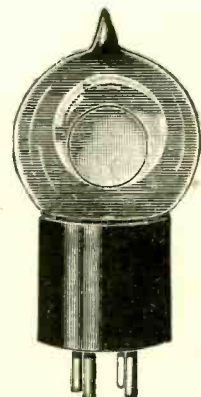

2-inch photo-electric cell for television transmission and for film recording of sound.

GUARANTY RADIO GOODS CO.,  
143 West 45th Street, New York, N. Y.

Enclosed please find \$..... for which ship at once, on a 10-day money-back guarantee, the tubes checked off on list below:

- |  |   |   |   |
|--|---|---|---|
| <input type="checkbox"/> RX-1 @ \$1.00 | <input type="checkbox"/> RX-11 @ \$1.00 | <input type="checkbox"/> RX-21 @ \$1.00 | <input type="checkbox"/> RX-31 @ \$2.95   |
| <input type="checkbox"/> RX-2 @ 1.00   | <input type="checkbox"/> RX-12 @ 1.00   | <input type="checkbox"/> RX-22 @ 1.00   | <input type="checkbox"/> RX-32 @ 2.00     |
| <input type="checkbox"/> RX-3 @ 1.00   | <input type="checkbox"/> RX-13 @ 1.00   | <input type="checkbox"/> RX-23 @ 1.00   | <input type="checkbox"/> RX-33 @ 2.85     |
| <input type="checkbox"/> RX-4 @ 1.00   | <input type="checkbox"/> RX-14 @ 1.00   | <input type="checkbox"/> RX-24 @ 1.00   | <input type="checkbox"/> RX-34 @ 2.85     |
| <input type="checkbox"/> RX-5 @ 1.00   | <input type="checkbox"/> RX-15 @ 1.00   | <input type="checkbox"/> RX-25 @ 1.00   | <input type="checkbox"/> RX-35 @ 4.95     |
| <input type="checkbox"/> RX-6 @ 1.00   | <input type="checkbox"/> RX-16 @ 1.00   | <input type="checkbox"/> RX-26 @ 2.95   | <input type="checkbox"/> RX-36 @ 4.95     |
| <input type="checkbox"/> RX-7 @ 1.00   | <input type="checkbox"/> RX-17 @ 1.00   | <input type="checkbox"/> RX-27 @ 2.00   | <input type="checkbox"/> RX-37 @ 1.00     |
| <input type="checkbox"/> RX-8 @ 1.00   | <input type="checkbox"/> RX-18 @ 1.00   | <input type="checkbox"/> RX-28 @ 2.10   | <input type="checkbox"/> RX-38 @ 2.95     |
| <input type="checkbox"/> RX-9 @ 1.00   | <input type="checkbox"/> RX-19 @ 1.00   | <input type="checkbox"/> RX-29 @ 3.85   | <input type="checkbox"/> RX-39 @ 1.00     |
| <input type="checkbox"/> RX-10 @ 1.00  | <input type="checkbox"/> RX-20 @ 1.00   | <input type="checkbox"/> RX-30 @ 4.50   | <input type="checkbox"/> C. O. D. desired |

Name .....

Address .....

City .....

State .....